

User Manual

Revision 1.002
English

BACnet Slave / KNX - Converter

(Order Code: HD67802-KNX-BIP-B2, HD67802-KNX-BMSTP-B2)

for Website information:

www.adfweb.com?Product=HD67802

for Price information:

www.adfweb.com?Price=HD67802-KNX-BIP-B2

www.adfweb.com?Price=HD67802-KNX-BMSTP-B2

Benefits and Main Features:

- ⊕ Very easy to configure
- ⊕ Electrical isolation
- ⊕ Temperature range: -40°C/85°C (-40°F/185°F)



For others KNX products, see also the following links:

Converter KNX to

- www.adfweb.com?Product=HD67801
- www.adfweb.com?Product=HD67803
- www.adfweb.com?Product=HD67804
- www.adfweb.com?Product=HD67807
- www.adfweb.com?Product=HD67808
- www.adfweb.com?Product=HD67809
- www.adfweb.com?Product=HD67810
- www.adfweb.com?Product=HD67811
- www.adfweb.com?Product=HD67812
- www.adfweb.com?Product=HD67813
- www.adfweb.com?Product=HD67814
- www.adfweb.com?Product=HD67815
- www.adfweb.com?Product=HD67818
- www.adfweb.com?Product=HD67820
- www.adfweb.com?Product=HD67821

- (BACnet Master)**
- (CAN)**
- (CANopen)**
- (EtherNet/IP)**
- (DeviceNet Master)**
- (DeviceNet Slave)**
- (J1939)**
- (M-Bus Master)**
- (Modbus Master)**
- (Modbus Slave)**
- (Modbus TCP Master)**
- (Modbus TCP Slave)**
- (PROFINET)**
- (SNMP)**
- (DMX)**

Do you have an your customer protocol?

www.adfweb.com?Product=HD67003

Do you need to choose a device? do you want help?

www.adfweb.com?Cmd=helpme



User Manual

INDEX:

| | Page |
|----------------------------------|------|
| INDEX | 2 |
| UPDATED DOCUMENTATION | 2 |
| REVISION LIST | 2 |
| WARNING | 2 |
| TRADEMARKS | 2 |
| SECURITY ALERT | 3 |
| EXAMPLE OF CONNECTION | 4 |
| CONNECTION SCHEME | 5 |
| CHARACTERISTICS | 7 |
| CONFIGURATION | 7 |
| POWER SUPPLY | 8 |
| FUNCTION MODES | 9 |
| LEDS | 10 |
| RS485 | 11 |
| KNX | 12 |
| ETHERNET | 13 |
| USE OF COMPOSITOR SW67802 | 14 |
| NEW PROJECT / OPEN PROJECT | 15 |
| SOFTWARE OPTIONS | 16 |
| SET COMMUNICATION | 17 |
| KNX ACCESS | 19 |
| SET BACNET ACCESS | 21 |
| UPDATE DEVICE | 23 |
| MECHANICAL DIMENSIONS | 25 |
| ORDERING INFORMATIONS | 26 |
| ACCESSORIES | 26 |
| DISCLAIMER | 27 |
| OTHER REGULATIONS AND STANDARDS | 27 |
| WARRANTIES AND TECHNICAL SUPPORT | 28 |
| RETURN POLICY | 28 |

UPDATED DOCUMENTATION:

Dear customer, we thank you for your attention and we remind you that you need to check that the following document is:

- ✚ Updated
- ✚ Related to the product you own

To obtain the most recently updated document, note the “document code” that appears at the top right-hand corner of each page of this document.

With this “Document Code” go to web page www.adfweb.com/download/ and search for the corresponding code on the page. Click on the proper “Document Code” and download the updates.

REVISION LIST:

| Revision | Date | Author | Chapter | Description |
|----------|------------|--------|---------|---------------|
| 1.000 | 20/04/2015 | Ff | All | First Release |
| 1.001 | 11/09/2015 | Ff | All | Revision |
| 1.002 | 26/02/2016 | Nt | All | Revision |

WARNING:

ADFweb.com reserves the right to change information in this manual about our product without warning.
ADFweb.com is not responsible for any error this manual may contain.

TRADEMARKS:

All trademarks mentioned in this document belong to their respective owners.

SECURITY ALERT:**GENERAL INFORMATION**

To ensure safe operation, the device must be operated according to the instructions in the manual. When using the device, legal and safety regulation are required for each individual application. The same applies also when using accessories.

INTENDED USE

Machines and systems must be designed so the faulty conditions do not lead to a dangerous situation for the operator (i.e. independent limit switches, mechanical interlocks, etc.).

QUALIFIED PERSONNEL

The device can be used only by qualified personnel, strictly in accordance with the specifications.

Qualified personnel are persons who are familiar with the installation, assembly, commissioning and operation of this equipment and who have appropriate qualifications for their job.

RESIDUAL RISKS

The device is state-of-the-art and is safe. The instruments can represent a potential hazard if they are inappropriately installed and operated by untrained personnel. These instructions refer to residual risks with the following symbol:



This symbol indicates that non-observance of the safety instructions is a danger for people that could lead to serious injury or death and / or the possibility of damage.

CE CONFORMITY

The declaration is made by our company. You can send an email to support@adfweb.com or give us a call if you need it.

EXAMPLE OF CONNECTION:

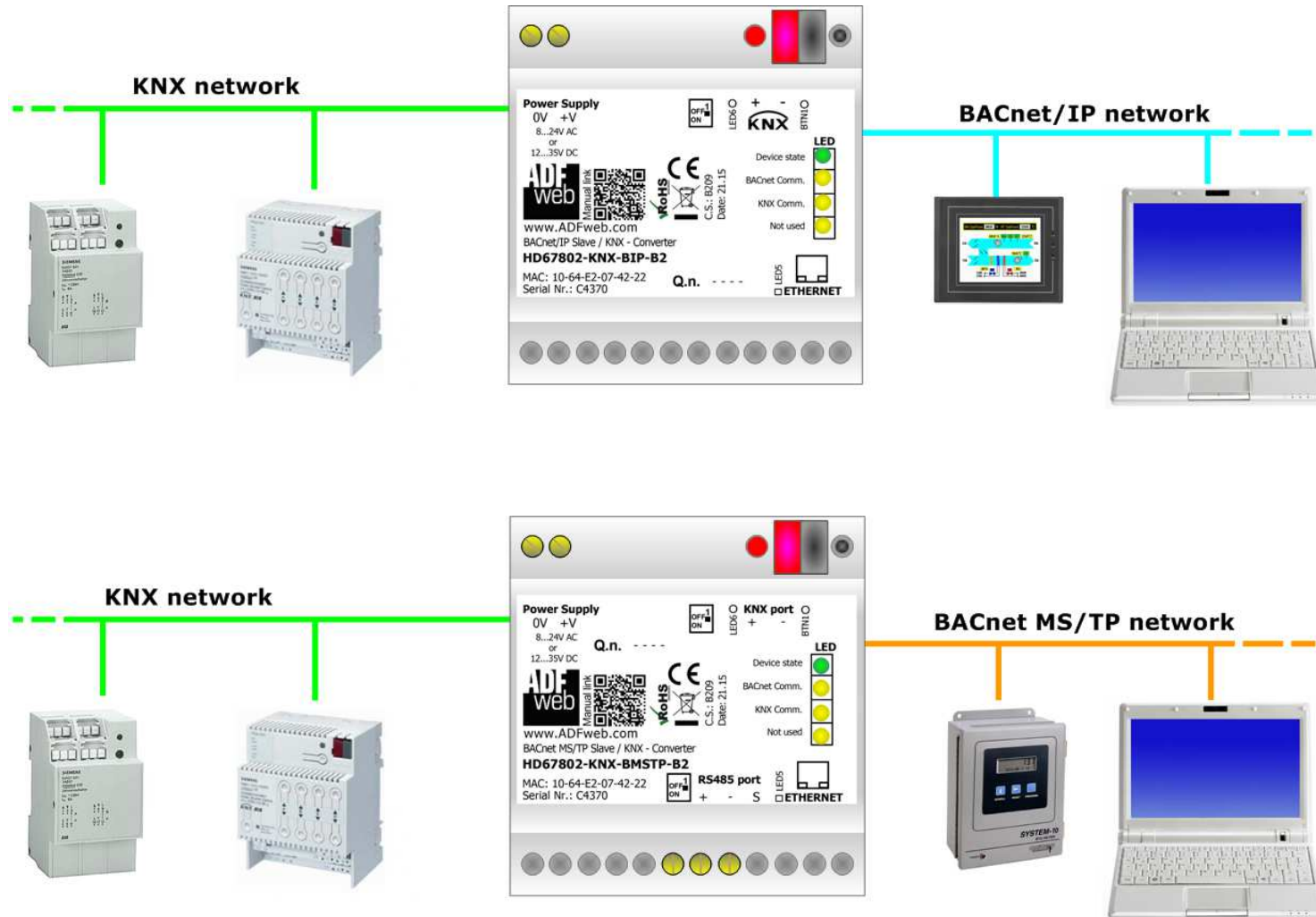

CONNECTION SCHEME:

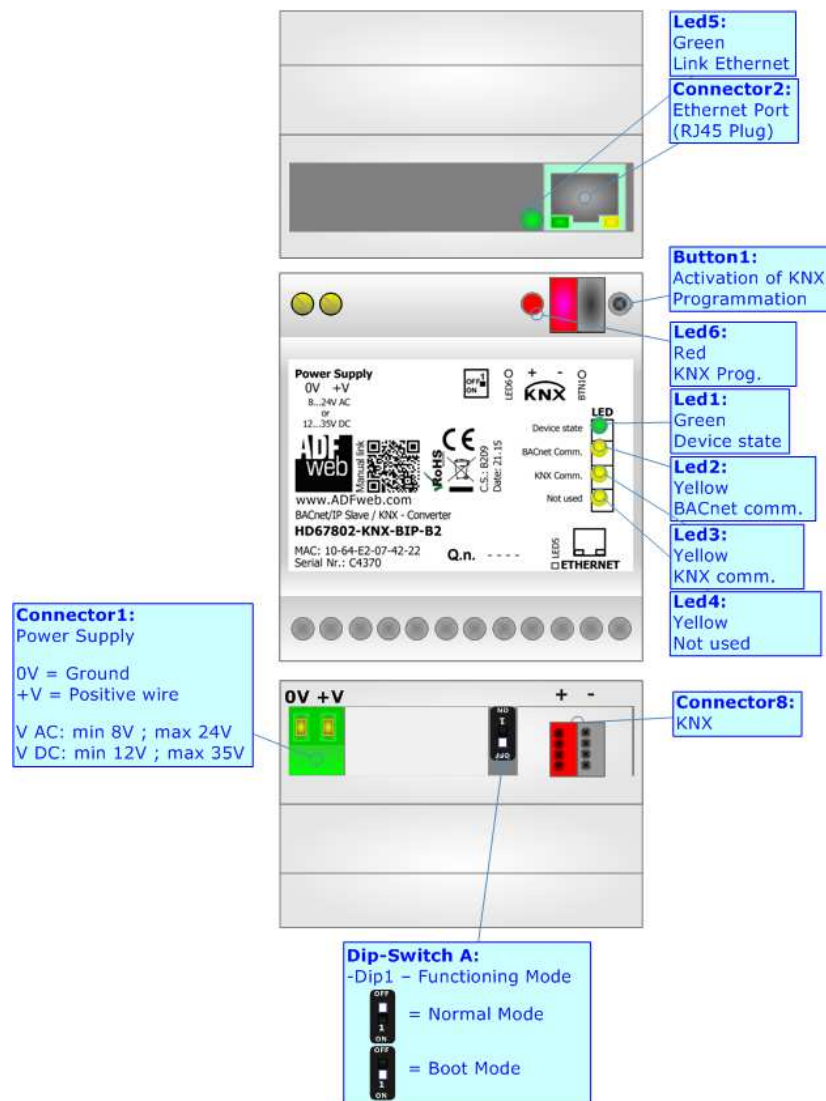

Figure 1a: Connection scheme for HD67802-KNX-BIP-B2

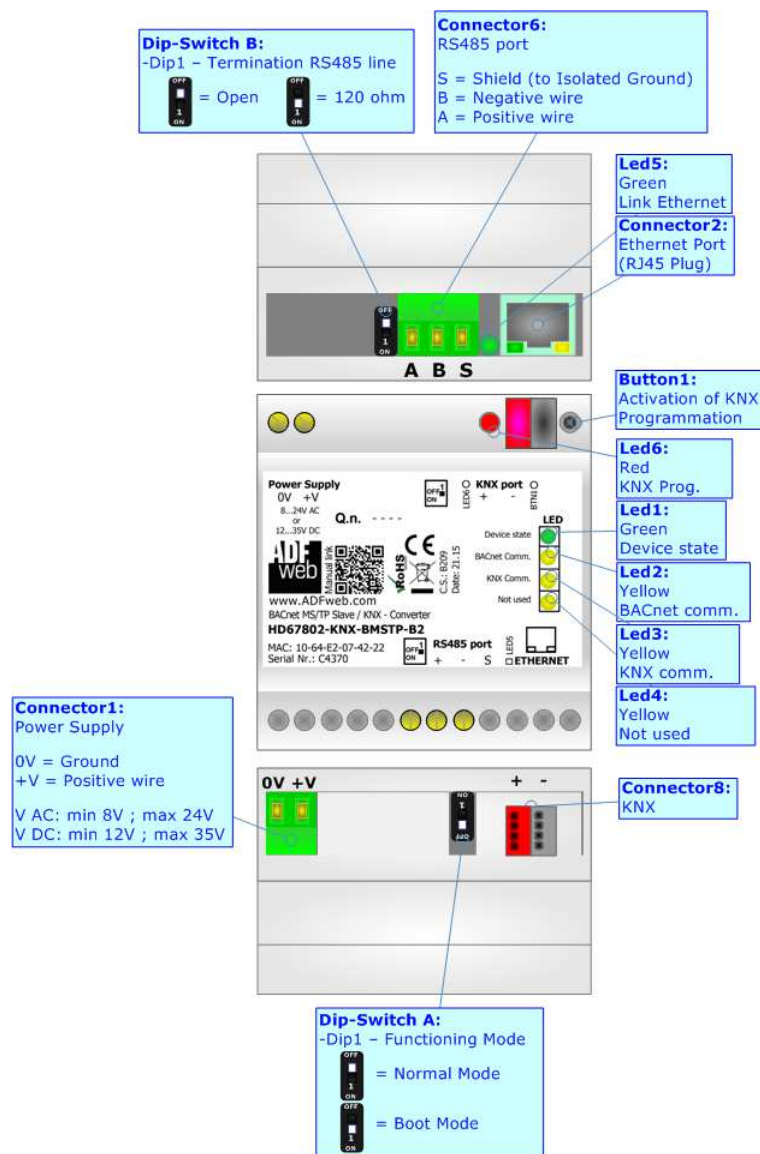

Figure 1b: Connection scheme for HD67802-KNX-BMSTP-B2

CHARACTERISTICS:

The HD67802 is a BACnet Slave / KNX Converter.

It has the following characteristics:

- Up to 1440 bytes in reading and 1440 bytes in writing;
- Triple isolation between KNX - Power Supply, KNX - BACnet, Power Supply - BACnet.
- Two-directional information between KNX bus and BACnet bus;
- Mountable on 35mm Rail DIN;
- Wide power supply input range: 8...24V AC or 12...35V DC;
- Wide temperature range: -40°C / 85°C [-40°F / +185°F].



CONFIGURATION:

You need Compositor SW67802 software on your PC in order to perform the following:

- Define the parameter of KNX line;
- Define the parameter of BACnet line;
- Define BACnet objects that contains the data from KNX;
- Define BACnet objects that contains the data to send to KNX;
- Update the device.

POWER SUPPLY:

The devices can be powered at 8...24V AC and 12...35V DC. For more details see the two tables below.

| VAC  | | VDC  | |
|---|------|---|------|
| Vmin | Vmax | Vmin | Vmax |
| 8V | 24V | 12V | 35V |

Consumption at 24V DC:

| Device | Consumption [W/VA] |
|----------------------|--------------------|
| HD67802-KNX-BIP-B2 | 3.5 |
| HD67802-KNX-BMSTP-B2 | 3.5 |

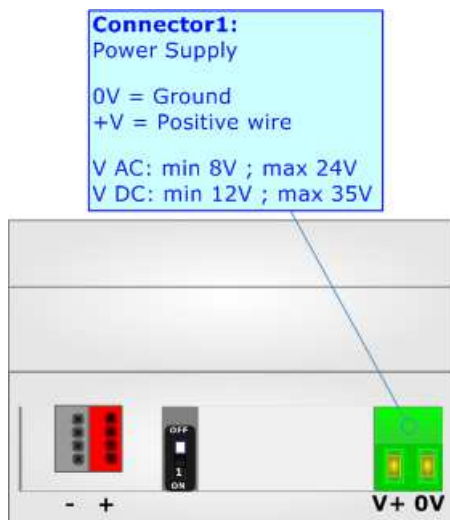

Caution: Not reverse the polarity power

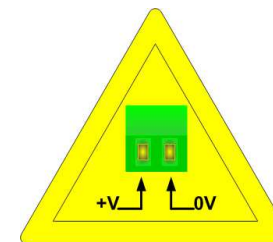

HD67802-KNX-BIP-B2
HD67802-KNX-BMSTP-B2

FUNCTION MODES:

The device has got two functions mode depending of the position of the 'Dip1 of Dip-Switch A':

- The first, with 'Dip1 of Dip-Switch A' at "OFF" position, is used for the normal working of the device.
- The second, with 'Dip1 of Dip-Switch A' at "ON" position, is used for upload the Project and/or Firmware.

For the operations to follow for the updating, see 'UPDATE DEVICE' section.

According to the functioning mode, the LEDs will have specifics functions, see 'LEDS' section.

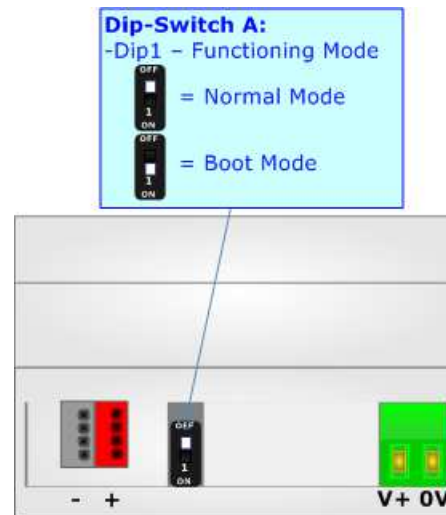

LEDS:

The device has got six LEDs that are used to give information of the functioning status. The various meanings of the LEDs are described in the table below.

| LED | Normal Mode | Boot Mode |
|----------------------------------|---|---|
| 1: Device State (green) | Blinks slowly (~1Hz) | ON: Device powered OFF: Device not powered |
| 2: BACnet communication (yellow) | Blinks when BACnet frame (RS232/RS485/Ethernet) is received | Blinks quickly: Boot state Blinks very slowly (~0.5Hz): update in progress |
| 3: KNX communication (yellow) | Blinks when KNX frame is received | Blinks quickly: Boot state Blinks very slowly (~0.5Hz): update in progress |
| 4: Not used (yellow) | OFF | Blinks quickly: Boot state Blinks very slowly (~0.5Hz): update in progress |
| 5: Ethernet Link (green) | ON: Ethernet cable connected OFF: Ethernet cable disconnected | ON: Ethernet cable connected OFF: Ethernet cable disconnected |
| 6: KNX Programmation (red) | ON: KNX Programmation activated OFF: KNX Programmation not activated | Blinks quickly: Boot state Blinks very slowly (~0.5Hz): update in progress |

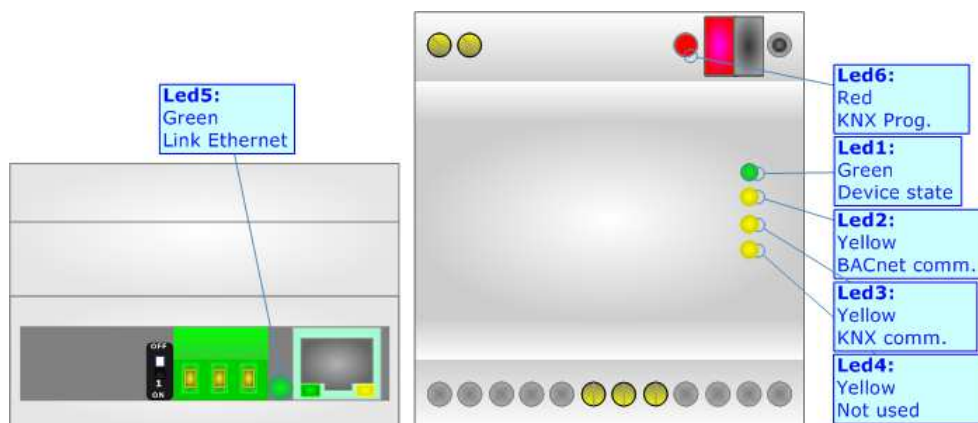

RS485:

For terminate the RS485 line with a 220Ω resistor it is necessary to put ON dip 1, like in figure.

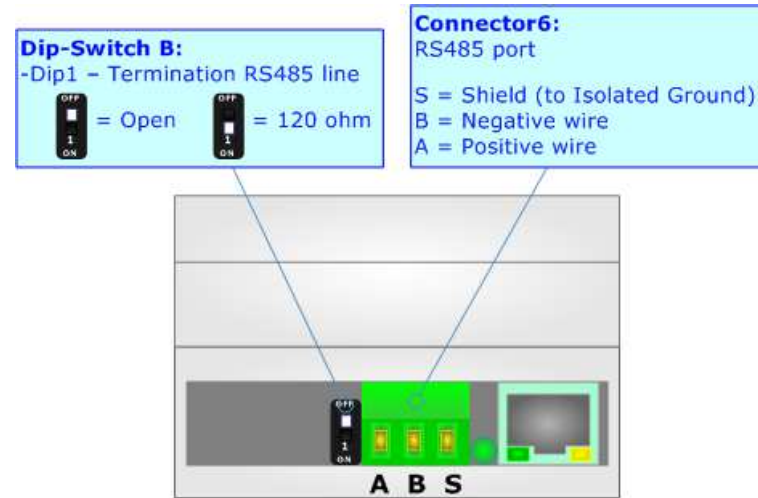

The maximum length of the cable should be 1200m (4000 feet).

Here some codes of cables:

- Belden: p/n 8132 - 2x 28AWG stranded twisted pairs conductor + foil shield + braid shield;
- Belden p/n 82842 - 2x 24AWG stranded twisted pairs conductor + foil shield + braid shield;
- Tasker: p/n C521 - 1x 24AWG twisted pair conductor + foil shield + braid shield;
- Tasker: p/n C522 - 2x 24AWG twisted pairs conductor + foil shield + braid shield.

KNX:

KNX is the standard that allows the automated and decentralized management of the technologic plans of a big typology of structures: commercial buildings, factories, houses, public locals, schools and so on. KNX can be used in all the applications and functions for the building automations: from lighting to control dampers, to the security, to the heating monitoring, to the conditioning, to the hydric control and alarms, to energy management and so on.

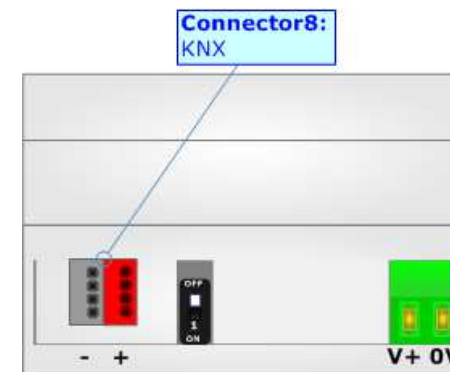

| Characteristics | Description TP1-256 |
|--|---|
| Medium | Shielded Twisted Pair |
| Topology | Linear, Star, Tree or mixed |
| Baudrate | 9600 bps |
| Device supplying | Normal: bus powered devices Optional: remote powered devices |
| Device power consumption | 3 mA- 12 mA |
| Power Supply Unit (PSU) | DC 30 V |
| Number of PSU's per physical Segment | Max. 2 |
| Number of connectable devices per physical Segment | Max. 256 |
| Number of addressable devices per physical Segment | Max. 255 |
| Total cable length per physical Segment | Max. 1000 m |
| Distance between two devices | Max. 700 m |

(*) Taken from KNX specifications

ETHERNET:

The Ethernet port is used for the BACnet/IP communication (HD67802-KNX-BIP-B2) and for programming the device.

The Ethernet connection must be made using Connector2 of HD67802-KNX-xxx-B2 with at least a Category 5E cable. The maximum length of the cable should not exceed 100m. The cable has to conform to the T568 norms relative to connections in cat.5 up to 100 Mbps. To connect the device to an Hub/Switch is recommended the use of a straight cable, to connect the device to a PC is recommended the use of a cross cable.

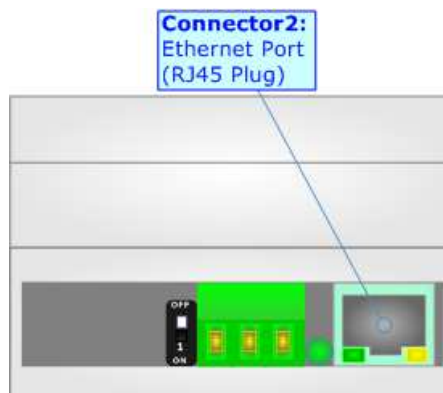

USE OF COMPOSITOR SW67802:

To configure the Converter, use the available software that runs with Windows called SW67802. It is downloadable on the site www.adfweb.com and its operation is described in this document. *(This manual is referenced to the last version of the software present on our web site).* The software works with MSWindows (XP, Vista, Seven, 8; 32/64bit).

When launching the SW67802, the window below appears (Fig. 2).



Note:

It is necessary to have installed .Net Framework 4.



Figure 2: Main window for SW67802

NEW CONFIGURATION / OPEN CONFIGURATION:

The “**New Configuration**” button creates the folder which contains the entire device’s configuration.

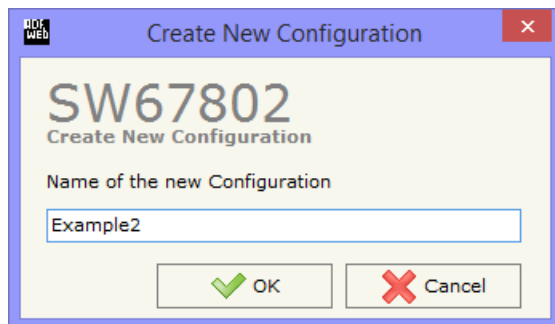

A device’s configuration can also be imported or exported:

- To clone the configurations of a Programmable “BACnet Slave / KNX - Converter” in order to configure another device in the same manner, it is necessary to maintain the folder and all its contents;
- To clone a project in order to obtain a different version of the project, it is sufficient to duplicate the project folder with another name and open the new folder with the button “**Open Configuration**”.

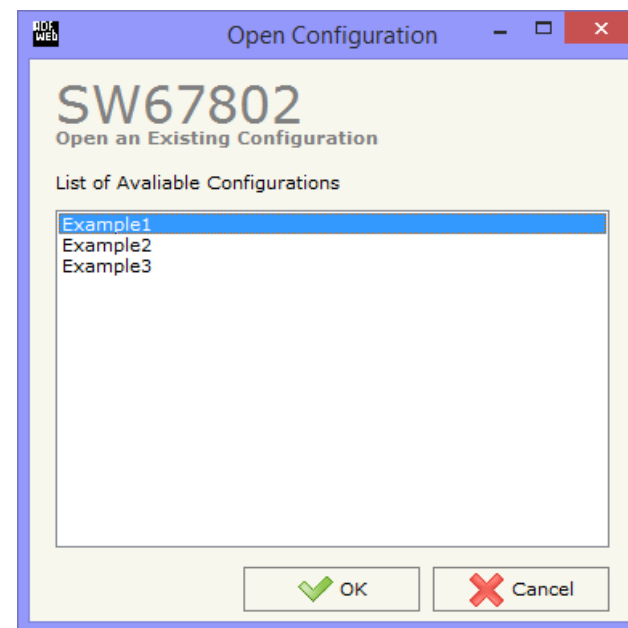

SOFTWARE OPTIONS:

By pressing the “**Settings**” () button there is the possibility to change the language of the software and check the updatings for the compositor.

In the section “Language” it is possible to change the language of the software.

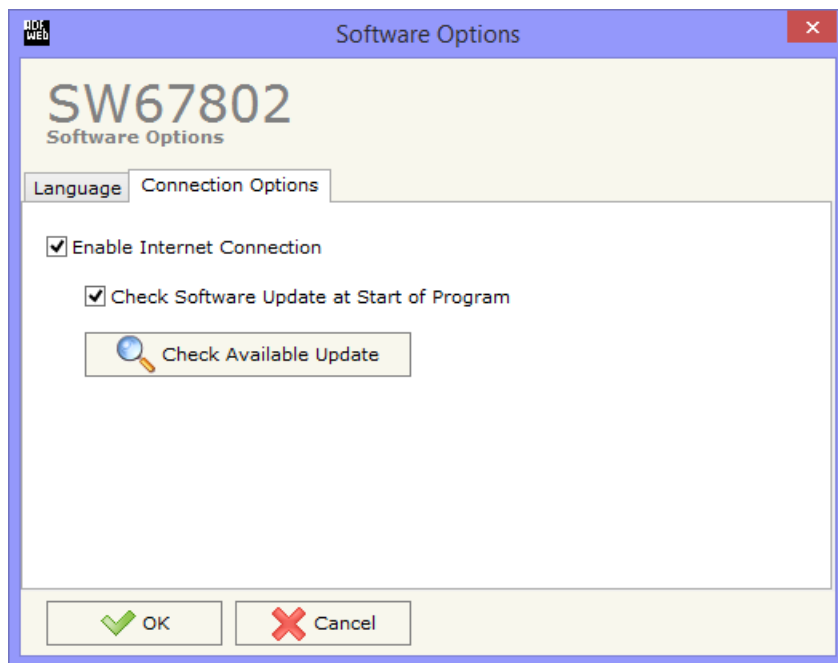

In the section “Connection Options”, it is possible to check if there are some updatings of the software compositor in ADFweb.com website. Checking the option “**Check Software Update at Start of Program**”, the SW67802 check automatically if there are updatings when it is launched.

SET COMMUNICATION:

This section define the fundamental communication parameters of two buses, KNX and BACnet.

By Pressing the **"Set Communication"** button from the main window for SW67802 (Fig. 2) the window "Set Communication" appears (Fig. 3).

The window is divided in two sections, one for the KNX and one for the BACnet.

In the section "BACnet Type" is possible to select the type of BACnet to use from:

- BACnet/IP (it uses ethernet);
- BACnet MS/TP (it uses RS485).

If selected "BACnet/IP" the means of the fields for "BACnet" are:

- In the fields **"IP ADDRESS"** insert the IP address that you want to give to the Converter;
- In the fields **"SUBNET Mask"** insert the SubNet Mask;
- In the fields **"GATEWAY"** insert the default gateway that you want to use. This feature can be enabled or disabled pressing the Check Box field. This feature is used for going out of the net;
- In the field **"Port"** the port used for BACnet communication is defined. The default port used for BACnet communication is 47808, but is possible to insert any value (except 10000 and 10001);
- In the field **"BACnet Device Name"** is possible to assign a name to the BACnet node;
- In the field **"Device Identifier"** is possible to assign a number to the BACnet node (Used for the Device Identifier).

The screenshot shows a software window titled "Set Communication" for device SW67802. It is divided into two main sections: BACnet and KNX. The BACnet section is currently active and contains the following fields: "BACnet Type" (dropdown menu set to "BACnet/IP"), "IP ADDRESS" (four input boxes with values 192, 168, 0, 10), "SUBNET Mask" (four input boxes with values 255, 255, 255, 0), a checked "GATEWAY" checkbox with an input box containing 192.168.0.1, "Port" (input box with value 47808), "BACnet Device Name" (input box with value devicename1), and "Device Identifier" (input box with value 1). The KNX section is partially visible below, showing "Type" (dropdown menu set to "KNX TP") and "ID Device" (input box with value 1.1.200). At the bottom of the window are "OK" and "Cancel" buttons.

Figure 3: "Set Communication" window

If selected "BACnet MS/TP" the means of the fields for "BACnet" are:

- In the field "**Baudrate**" it is possible to select the baudrate of the BACnet (9600, 19200, 38400, 57600, 76800, 115200);
- In the field "**Parity**" it is possible to select the parity of the line (None, Odd, Even);
- In the field "**MAC Address**" is possible to define the MAC of BACnet node (from 0 to 254);
- In the field "**BACnet Device Name**" is possible to insert the name to give to the BACnet node (maximum 17 characters).

The means of the fields for the "Ethernet Update" section are:

- In the fields "**IP ADDRESS**" insert the IP address that you want to give to the Converter;
- In the fields "**SUBNET Mask**" insert the SubNet Mask;
- In the fields "**GATEWAY**" insert the default gateway that you want to use. This feature can be enabled or disabled pressing the Check Box field. This feature is used for going out of the net.

These information are used for programming the Converter.

The means of the fields for "KNX" are:

- In the field "**Type**" the type of KNX is defined (fixed to 'KNX TP');
- In the field "**ID Device**" the ID of the KNX side of the converter is defined.

SW67802
Set Communication Setting

BACnet Type
Type: BACnet MS/TP

BACnet
Baudrate: 115200
Parity: NONE
MAC Address: 0
BACnet Device Name: devicename1

Ethernet Update
IP ADDRESS: 192 . 168 . 0 . 10
SUBNET Mask: 255 . 255 . 255 . 0
 GATEWAY: 192 . 168 . 0 . 1

KNX
Type: KNX TP
ID Device: 1.1.200

OK Cancel

KNX ACCESS:

By pressing the **"KNX Access"** button from the main window for SW67802 (Fig. 2) the "KNX Access" window appears (Fig. 4).

The means of the fields are:

- ✦ If the field **"Enable"** is checked, the KNX message is enabled;
- ✦ In the field **"Source Address"** the Source Address to assign to the KNX message is defined;
- ✦ In the field **"Dest/Group"** the Group address (2 level structure, 3 level structure or free address structure) or the device address is defined. In case of Group address, the levels must be separated by '/', in case of Device address, the parts of the address must be separated by '.';
- ✦ In the field **"APCI"** the APCI of the KNX message is defined. You can choose between the following:
 - Read: it is used to send a reading request to a KNX device;
 - Write: it is used to send a writing request to a KNX device;
 - Specific value (edited manually).
- ✦ In the field **"Priority"** the Priority of the KNX message is defined. You can choose between the following:
 - System (Highest);
 - Urgent;
 - Normal;
 - Low (Lowest).
- ✦ In the field **"Format"** the data format of the KNX message is defined;
- ✦ If the field **"Extended"** is checked, the extended format of the KNX message is used;
- ✦ If the field **"ReTest"** is checked, the KNX message is re-sent in case of not correct response;
- ✦ If the field **"On CMD"** is checked, the gateway sends the KNX command when a BACnet request is received;
- ✦ If the field **"On Change"** is checked, the gateway sends the KNX command when the data on BACnet change the value;
- ✦ If the field **"On Timer"** is checked, the gateway sends the KNX command cyclically;
- ✦ In the field **"Poll Time"** the delay in ms between two KNX commands is defined (if "On Timer" is checked);
- ✦ In the field **"Position"** insert the address of the internal array where placing the information;

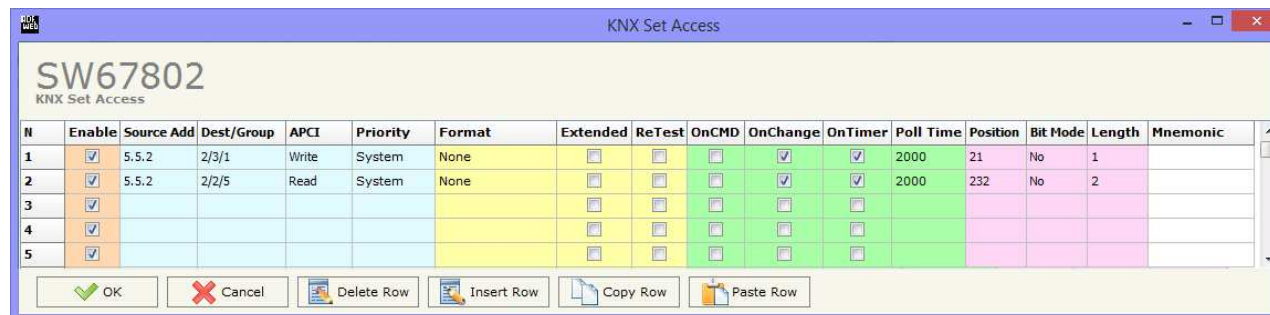



Figure 4: "KNX Set Access" window

- ✦ In the field "**Bit Mode**" insert the start bit of the first byte of the field "Position" where start to insert the data read;
- ✦ In the field "**Lenght**" the dimension of the KNX message is defined;
- ✦ In the field "**Mnemonic**" the description for the request is defined.

 Note:
If the field "On change" is checked and the "Poll Time" is different from 0, the converter sends the KNX command cyclically and also when the data is changed.

 Note:
If the fields "On CMD", "OnChange" and "OnTimer" are not checked, the converter only sniffs the bus in order to monitor the status of the KNX message.

SET BACNET ACCESS:

By Pressing the **“Set BACnet Access”** button from the main window for SW67802 (Fig. 2) the window **“BACnet Set Access”** appears (Fig. 5).

The window is divided in two parts, the **“BACnet in Read”** that contains the BACnet objects readable by a BACnet Master (the KNX messages associated to these objects are read by BACnet Master); and **“BACnet in Write”** that contains the BACnet objects writable by a BACnet Master (the KNX messages associated to these objects are written by BACnet Master).

The meaning of the fields in the window are the follows:

- In the field **“Data Type”** is possible to select the BACnet object data type;
- In the field **“Eng. Unit”**, with double click the window *“Select the BACnet Engineering Unit”* appears (Fig. 5);
- In the field **“Position”** is possible to select the position where take/save the data from a 6000 bytes array;
- The field **“Start Bit”** is used for the *“Binary In”* and *“Binary Out”* BACnet objects;
- The field **“Length”** is used for all the others BACnet objects.

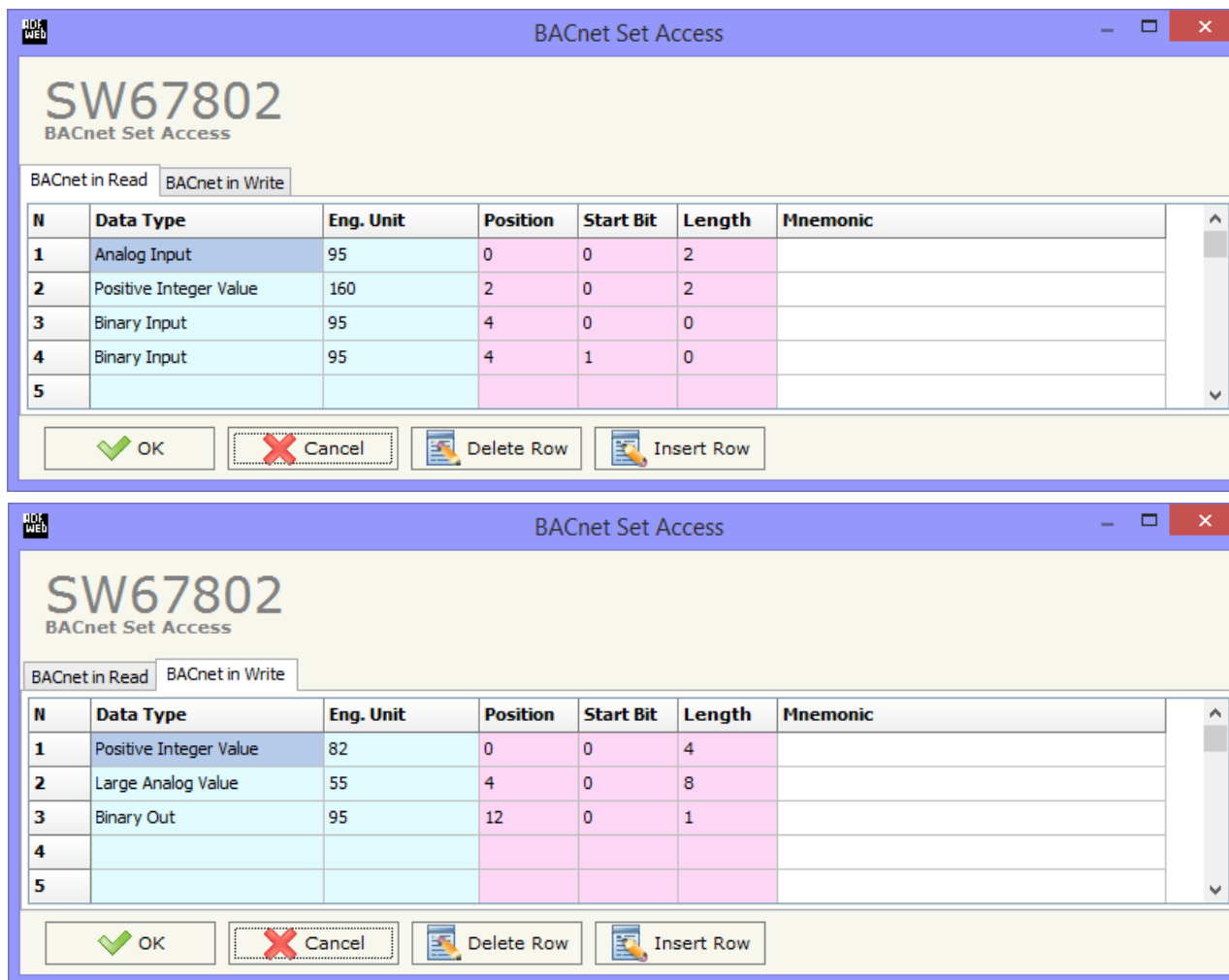

Figure 5: *“BACnet Set Access”* window

Is possible to insert directly the Unit (using its unique number) by compiling the **"Selected BACnet Engineering Unit"** field; or by selecting with the fields **"Select the Type"** and **"Select unit"** the Type/Unit desired. If the second way is used, is necessary to press the **"Select Engineering Unit"** button for confirm the choice.

The screenshot shows a dialog box titled "Select the BACnet Engineering Unit". At the top left of the dialog is the ADFweb logo. The main content area displays "SW67802" and "Select the BACnet Engineering Unit". Below this, there is a text field labeled "Selected BACnet Engineering Unit" containing the value "166", followed by the text "-> meters-per-second-per-second". A horizontal line separates this from the "Select a New BACnet Engineering Unit" section. This section contains two dropdown menus: "Select the Type" is set to "Acceleration" and "Select Unit" is set to "meters-per-second-per-second". Below these dropdowns is a button labeled "Select Engineering Unit". At the bottom of the dialog are two buttons: "OK" with a green checkmark icon and "Cancel" with a red X icon.

Figure 5: "Select the BACnet Engineering Unit" window

UPDATE DEVICE:

By pressing the **"Update Device"** button, it is possible to load the created Configuration into the device; and also the Firmware, if necessary.

If you don't know the actual IP address of the device you have to use this procedure:

- Turn off the Device;
- Put Dip1 of 'Dip-Switch A' in ON position;
- Turn on the device
- Connect the Ethernet cable;
- Insert the IP **"192.168.2.205"**;
- Press the **"Ping"** button, "Device Found!" must appear;
- Press the **"Next"** button;
- Select which operations you want to do;
- Press the **"Execute update firmware"** button to start the upload;
- When all the operations are "OK" turn off the Device;
- Put Dip1 of 'Dip-Switch A' at OFF position;
- Turn on the device.

At this point the configuration/firmware on the device is correctly updated.

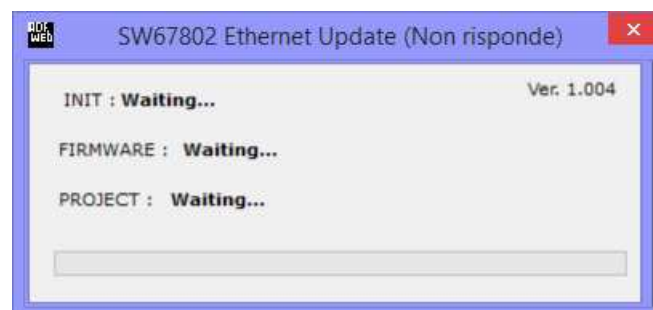
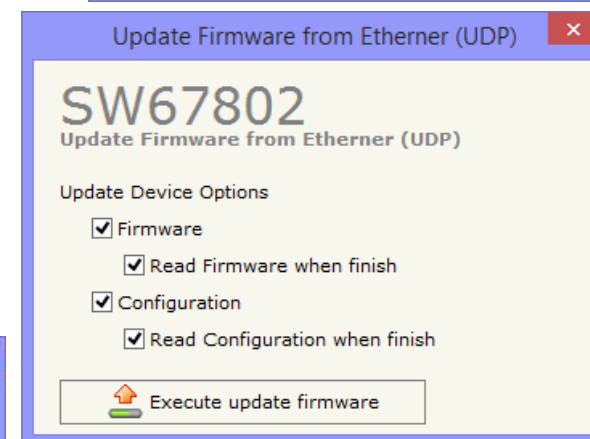
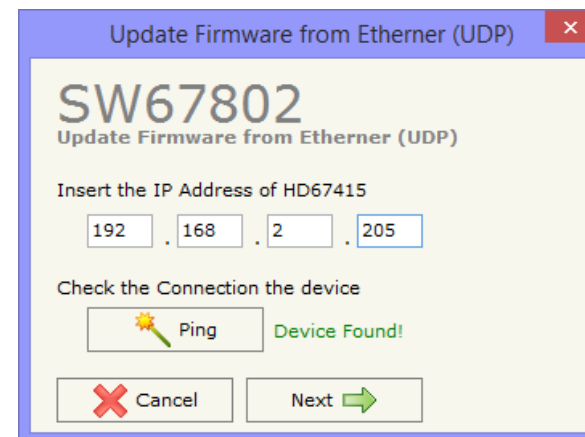

Figure 8: "Update device" windows

If you know the actual IP address of the device, you have to use this procedure:

- Turn on the Device with the Ethernet cable inserted;
- Insert the actual IP of the Converter;
- Press the "**Ping**" button, must appear "Device Found!";
- Press the "**Next**" button;
- Select which operations you want to do;
- Press the "**Execute update firmware**" button to start the upload;
- When all the operations are "OK" the device automatically goes at Normal Mode.

At this point the configuration/firmware on the device is correctly update.



Note:

When you install a new version of the software, if it is the first time it is better you do the update of the Firmware in the HD67802 device.



Note:

When you receive the device, for the first time, you also have to update the Firmware in the HD67802 device.



Warning:

If Fig. 9 appears when you try to do the Update try these points before seeking assistance:

- Try to repeat the operations for the updating;
- Try with another PC;
- Try to restart the PC;
- If you are using the program inside a Virtual Machine, try to use in the main Operating System;
- If you are using Windows Seven or Vista or 8, make sure that you have the administrator privileges;
- Take attention at Firewall lock;
- Check the LAN settings.



In the case of HD67802 you have to use the software "SW67802": www.adfweb.com/download/filefold/SW67802.zip.

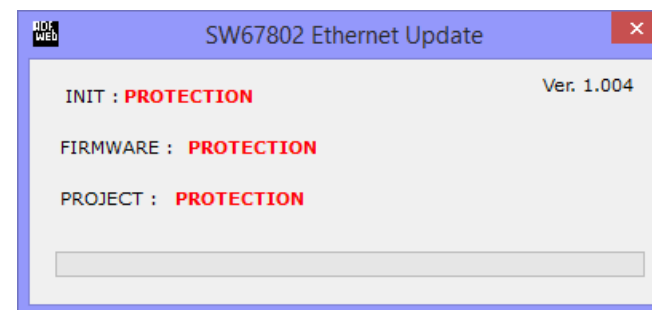
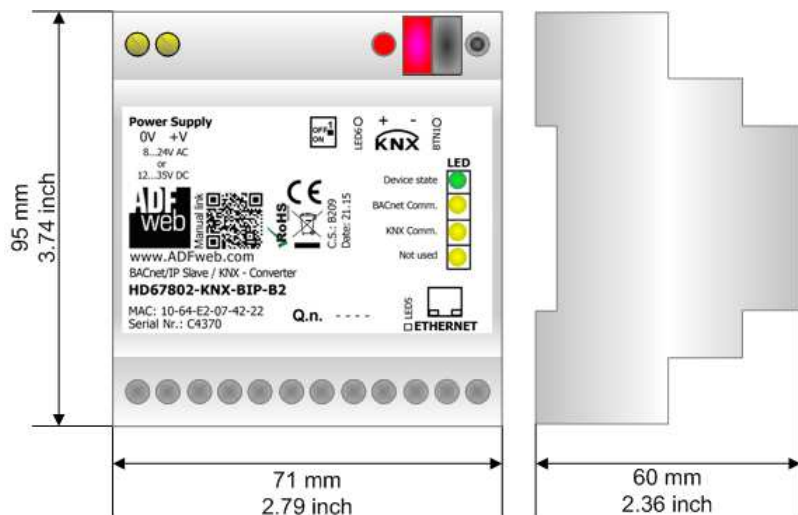
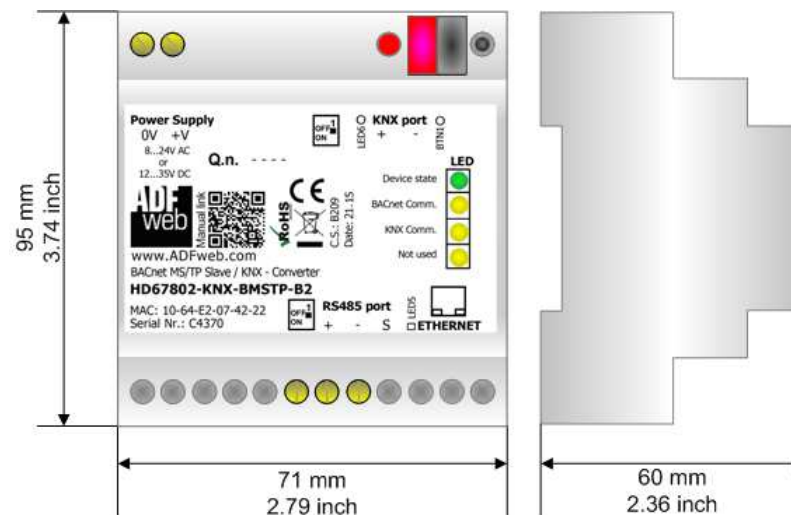

Figure 9: "Protection" window

MECHANICAL DIMENSIONS:



Housing: PVC
Weight: 200g (Approx)



Housing: PVC
Weight: 200g (Approx)

Figure 10a: Mechanical dimensions scheme for HD67802-KNX-BIP-B2

Figure 10b: Mechanical dimensions scheme for HD67802-KNX-BMSTP-B2

ORDERING INFORMATIONS:

The ordering part number is formed by a valid combination of the following:

HD67802 – KNX – xxx – B 2

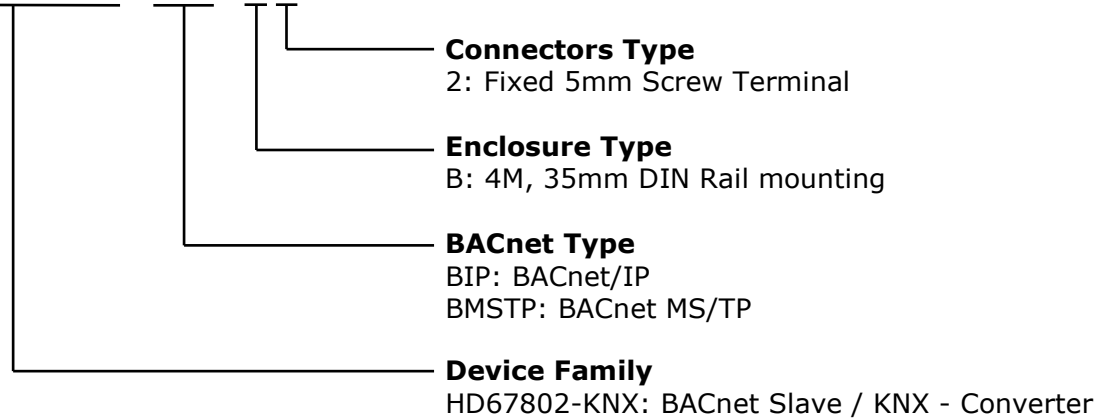

- Order Code: **HD67802-KNX-BIP-B2** - BACnet/IP Slave / KNX – Converter
- Order Code: **HD67802-KNX-BMSTP-B2** - BACnet MS/TP Slave / KNX – Converter

ACCESSORIES:

- Order Code: **AC34001** - 35mm Rail DIN - Power Supply 220/240V AC 50/60Hz – 12 V AC
- Order Code: **AC34002** - 35mm Rail DIN - Power Supply 110V AC 50/60Hz – 12 V AC

DISCLAIMER:

All technical content within this document can be modified without notice. The content of the document is a under continual renewal. For losses due to fire, earthquake, third party access or other accidents, or intentional or accidental abuse, misuse, or use under abnormal conditions repairs are charged to the user. ADFweb.com S.r.l. will not be liable for accidental loss of use or inability to use this product, such as loss of business income. ADFweb.com S.r.l. shall not be liable for consequences of improper use.

OTHER REGULATIONS AND STANDARDS:**WEEE INFORMATION**

Disposal of old electrical and electronic equipment (as in the European Union and other European countries with separate collection systems).

— This symbol on the product or on its packaging indicates that this product may not be treated as household rubbish. Instead, it should be taken to an applicable collection point for the recycling of electrical and electronic equipment. If the product is disposed correctly, you will help prevent potential negative environmental factors and impact of human health, which could otherwise be caused by inappropriate disposal. The recycling of materials will help to conserve natural resources. For more information about recycling this product, please contact your local city office, your household waste disposal service or the shop where you purchased the product.

RESTRICTION OF HAZARDOUS SUBSTANCES DIRECTIVE

The device respects the 2002/95/EC Directive on the restriction of the use of certain hazardous substances in electrical and electronic equipment (commonly referred to as Restriction of Hazardous Substances Directive or RoHS).

CE MARKING

The product conforms with the essential requirements of the applicable EC directives.

WARRANTIES AND TECHNICAL SUPPORT:

For fast and easy technical support for your ADFweb.com SRL products, consult our internet support at www.adfweb.com.
Otherwise contact us at the address support@adfweb.com

RETURN POLICY:

If while using your product you have any problem and you wish to exchange or repair it, please do the following:

- Obtain a Product Return Number (PRN) from our internet support at www.adfweb.com. Together with the request, you need to provide detailed information about the problem.
- Send the product to the address provided with the PRN, having prepaid the shipping costs (shipment costs billed to us will not be accepted).

If the product is within the warranty of twelve months, it will be repaired or exchanged and returned within three weeks. If the product is no longer under warranty, you will receive a repair estimate.



ADFweb.com S.r.l.
Via Strada Nuova, 17
IT-31010 Mareno di Piave
TREVISO (Italy)
Phone +39.0438.30.91.31
Fax +39.0438.49.20.99
www.adfweb.com

