

User Manual

Revision 1.000
English

SNMP Manager / CANopen - Converter

(Order Code: HD67172-A1, HD67172-B2)

for Website information:

www.adfweb.com?Product=HD67172

for Price information:

www.adfweb.com?Price=HD67172-A1

www.adfweb.com?Price=HD67172-B2

Benefits and Main Features:

- ✦ Very easy to configure
- ✦ Electrical isolation
- ✦ Temperature range: -40°C/85°C (-40°F/185°F)

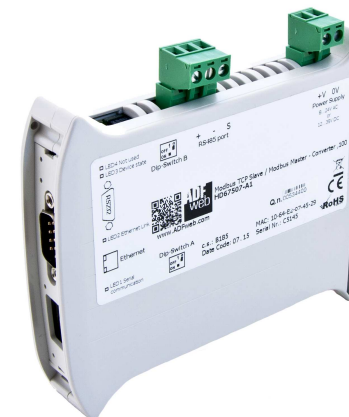

For others SNMP Manager products, see also the following links:

Converter SNMP Manager to

- www.adfweb.com?Product=HD67170
- www.adfweb.com?Product=HD67171
- www.adfweb.com?Product=HD67849
- www.adfweb.com?Product=HD67041
- www.adfweb.com?Product=HD67173
- www.adfweb.com?Product=HD67174
- www.adfweb.com?Product=HD67175
- www.adfweb.com?Product=HD67176
- www.adfweb.com?Product=HD67177
- www.adfweb.com?Product=HD67178

- (BACnet Slave)**
- (CAN)**
- (DALI)**
- (DMX)**
- (DeviceNet Slave)**
- (EtherNet/IP)**
- (Modbus Slave)**
- (Modbus TCP Slave)**
- (PROFIBUS Slave)**
- (PROFINET)**

Do you have an your customer protocol?

www.adfweb.com?Product=HD67003

Do you need to choose a device? do you want help?

www.adfweb.com?Cmd=helpme



User Manual

INDEX:

	Page
INDEX	2
UPDATED DOCUMENTATION	2
REVISION LIST	2
WARNING	2
TRADEMARKS	2
SECURITY ALERT	3
EXAMPLE OF CONNECTION	4
CONNECTION SCHEME	5
CHARACTERISTICS	7
CONFIGURATION	7
POWER SUPPLY	8
FUNCTION MODES	9
LEDS	10
ETHERNET	11
CANOPEN	12
USE OF COMPOSITOR SW67172	13
NEW PROJECT / OPEN PROJECT	14
SOFTWARE OPTIONS	15
SET COMMUNICATION	17
SNMP MANAGER	18
SET SDO SERVER	20
SET SDO CLIENT	21
SET PDO ACCESS	23
EDS FILE	24
UPDATE DEVICE	25
MECHANICAL DIMENSIONS	27
ORDERING INFORMATIONS	28
ACCESSORIES	28
DISCLAIMER	29
OTHER REGULATIONS AND STANDARDS	29
WARRANTIES AND TECHNICAL SUPPORT	30
RETURN POLICY	30

UPDATED DOCUMENTATION:

Dear customer, we thank you for your attention and we remind you that you need to check that the following document is:

- ✚ Updated
- ✚ Related to the product you own

To obtain the most recently updated document, note the “document code” that appears at the top right-hand corner of each page of this document.

With this “Document Code” go to web page www.adfweb.com/download/ and search for the corresponding code on the page. Click on the proper “Document Code” and download the updates.

REVISION LIST:

Revision	Date	Author	Chapter	Description
1.000	09/03/2016	Ff	All	First Release

WARNING:

ADFweb.com reserves the right to change information in this manual about our product without warning.
ADFweb.com is not responsible for any error this manual may contain.

TRADEMARKS:

All trademarks mentioned in this document belong to their respective owners.

SECURITY ALERT:**GENERAL INFORMATION**

To ensure safe operation, the device must be operated according to the instructions in the manual. When using the device, legal and safety regulation are required for each individual application. The same applies also when using accessories.

INTENDED USE

Machines and systems must be designed so the faulty conditions do not lead to a dangerous situation for the operator (i.e. independent limit switches, mechanical interlocks, etc.).

QUALIFIED PERSONNEL

The device can be used only by qualified personnel, strictly in accordance with the specifications. Qualified personnel are persons who are familiar with the installation, assembly, commissioning and operation of this equipment and who have appropriate qualifications for their job.

RESIDUAL RISKS

The device is state-of-the-art and is safe. The instruments can represent a potential hazard if they are inappropriately installed and operated by untrained personnel. These instructions refer to residual risks with the following symbol:



This symbol indicates that non-observance of the safety instructions is a danger for people that could lead to serious injury or death and / or the possibility of damage.

CE CONFORMITY

The declaration is made by our company. You can send an email to support@adfweb.com or give us a call if you need it.

EXAMPLE OF CONNECTION:

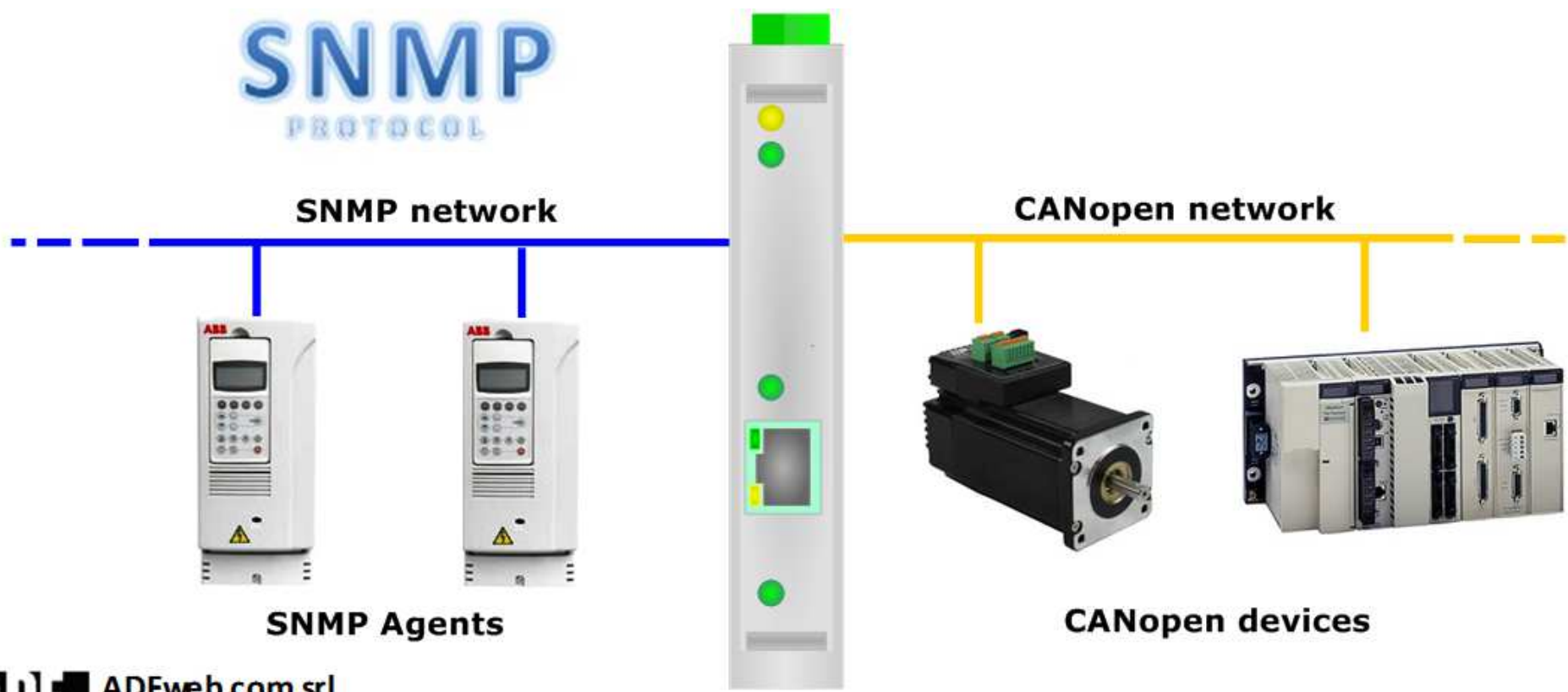

ADFweb ADFweb.com srl
 tel. +39 - 0438.30.91.31
 www.adfweb.com
 info@adfweb.com

HD67172-A1

CONNECTION SCHEME:

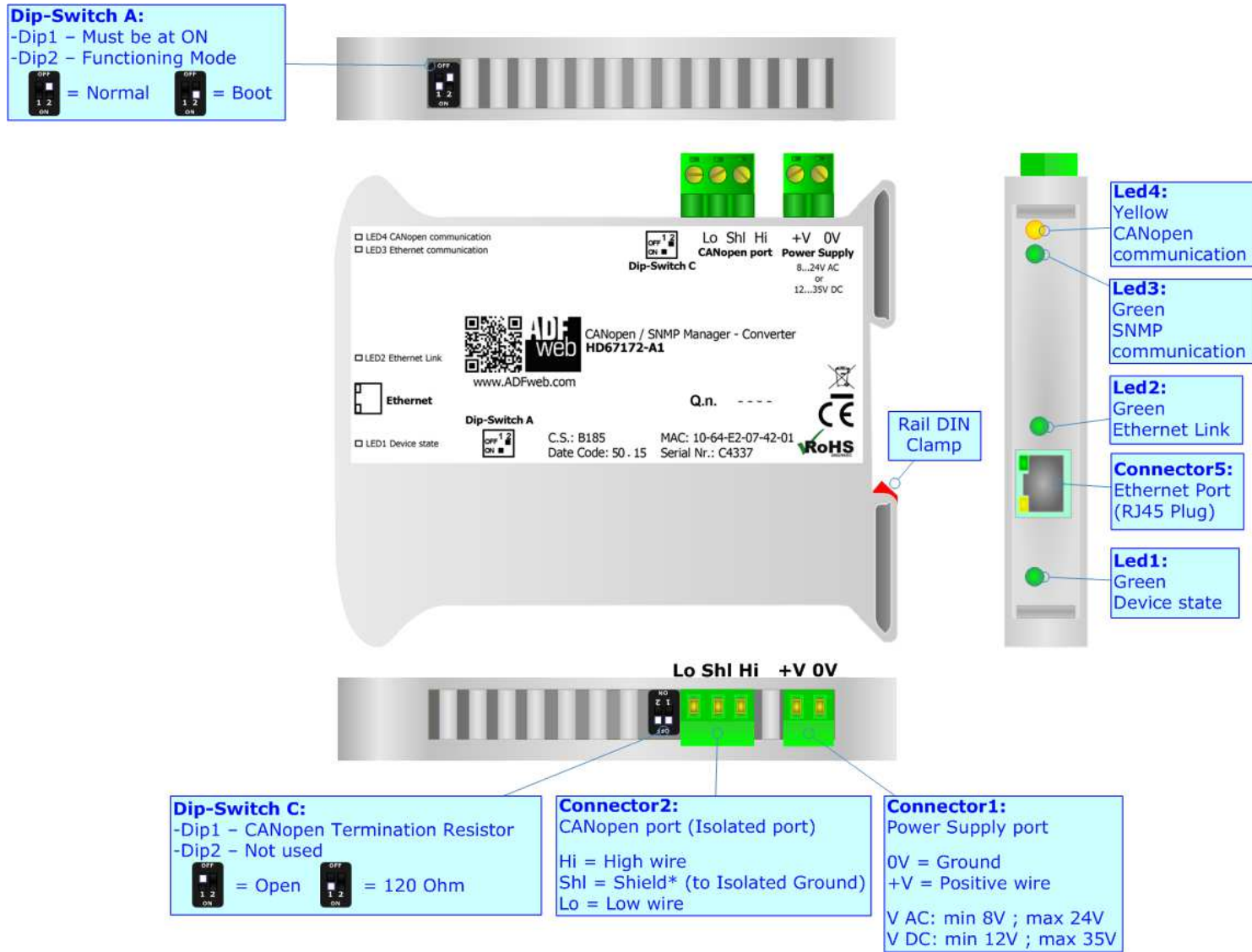

Figure 1a: Connection scheme for HD67172-A1

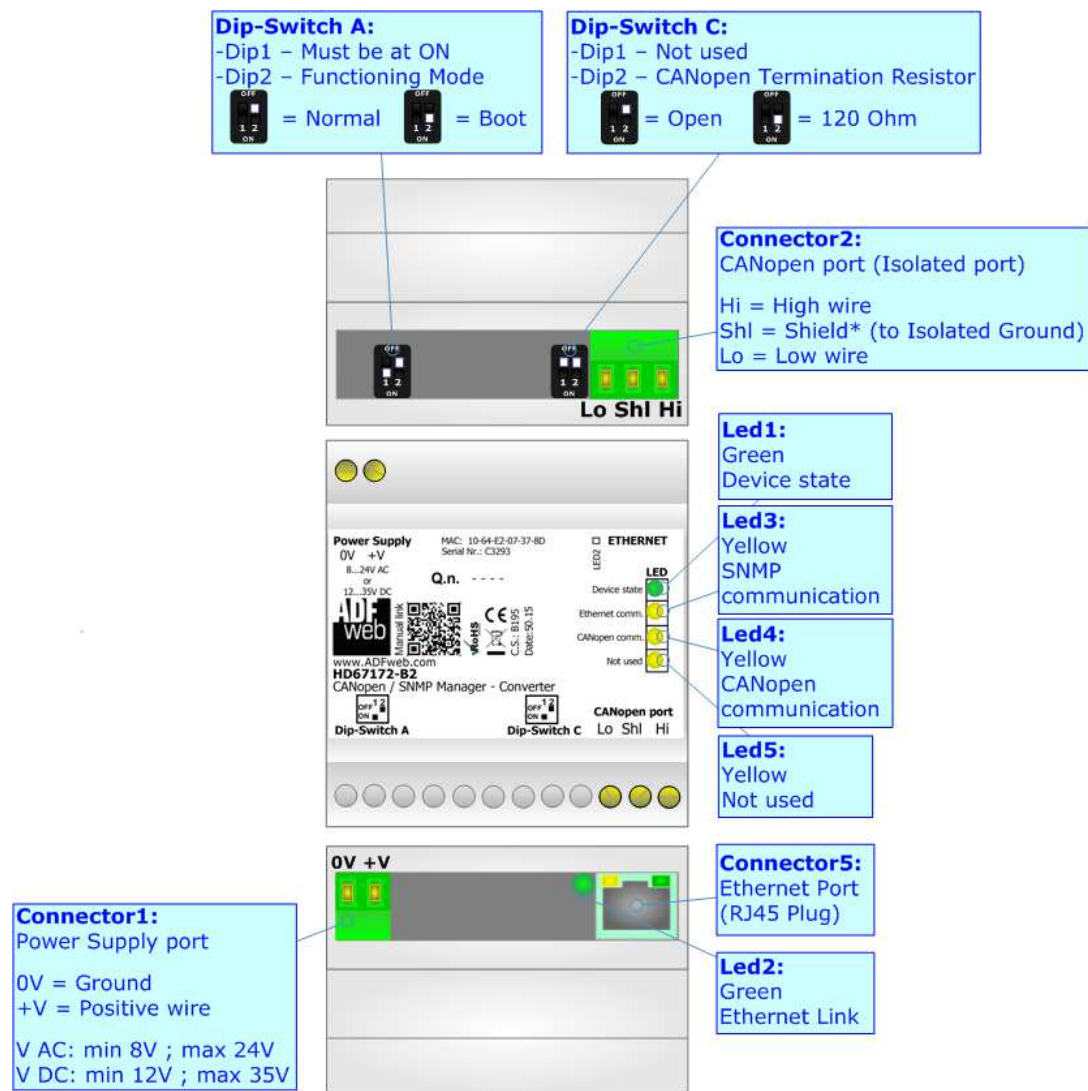

Figure 1b: Connection scheme for HD67172-B2

CHARACTERISTICS:

The HD67172 is a SNMP Manager / CANopen - Converter.

It has the following characteristics:

- Up to 2000 bytes in reading and 2000 bytes in writing;
- Isolation between Power Supply – Ethernet, Ethernet – CAN, Power Supply - CAN.
- Two-directional information between CANopen bus and SNMP bus;
- Mountable on 35mm Rail DIN;
- Wide power supply input range: 8...24V AC or 12...35V DC;
- Wide temperature range: -40°C / 85°C [-40°F / +185°F].

CONFIGURATION:

You need Compositor SW67172 software on your PC in order to perform the following:

- Define the parameter of SNMP line;
- Define the parameter of CANopen line;
- Define the SNMP requests to send to the SNMP Agents;
- Define the CANopen Objects in reading and in writing;
- Update the device.

POWER SUPPLY:

The devices can be powered at 8...24V AC and 12...35V DC. For more details see the two tables below.

VAC		VDC	
Vmin	Vmax	Vmin	Vmax
8V	24V	12V	35V

Consumption at 24V DC:

Device	Consumption [W/VA]
HD67172-A1	3.5
HD67172-B2	3.5

Connector1:
 Power Supply port
 0V = Ground
 +V = Positive wire
 V AC: min 8V ; max 24V
 V DC: min 12V ; max 35V

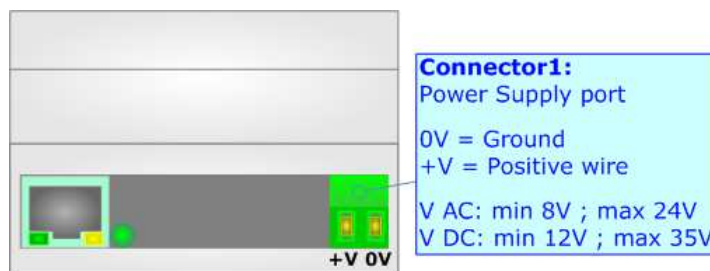

Connector1:
 Power Supply port
 0V = Ground
 +V = Positive wire
 V AC: min 8V ; max 24V
 V DC: min 12V ; max 35V

Caution: Not reverse the polarity power

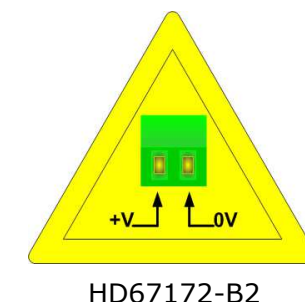
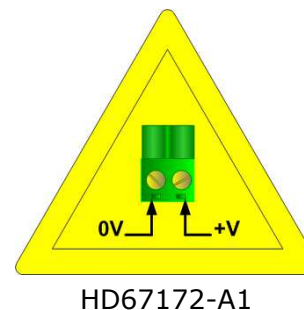

FUNCTION MODES:

The device has got two functions mode depending of the position of the 'Dip2 of Dip-Switch A':

- The first, with 'Dip2 of Dip-Switch A' at "OFF" position, is used for the normal working of the device.
- The second, with 'Dip2 of Dip-Switch A' at "ON" position, is used for upload the Project and/or Firmware.

For the operations to follow for the updating, see 'UPDATE DEVICE' section.

According to the functioning mode, the LEDs will have specifics functions, see 'LEDS' section.

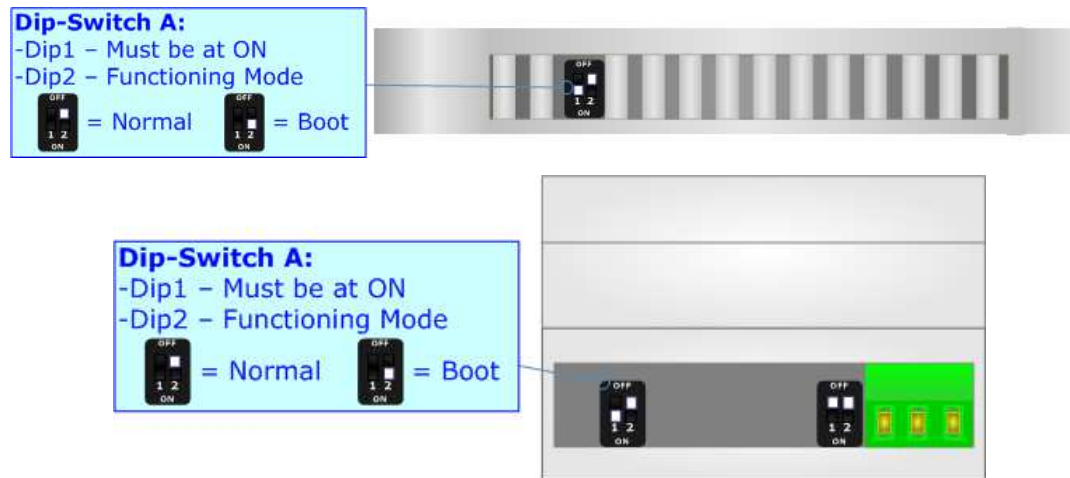

Warning:
 Dip1 of 'Dip-Switch A' must be at ON position for working even if the Ethernet cable isn't inserted.

LEDS:

The devices have got four (five for HD67172-B2) LEDs that are used to give information of the functioning status. The various meanings of the LEDs are described in the table below.

LED	Normal Mode	Boot Mode
1: Device state (green)	Blinks slowly (~1Hz)	Blinks quickly: Boot state Blinks very slowly (~0.5Hz): update in progress
2: Ethernet Link (green)	ON: Ethernet cable connected OFF: Ethernet cable disconnected	ON: Ethernet cable connected OFF: Ethernet cable disconnected
3: SNMP communication (green)	Blinks when a SNMP response is received	Blinks quickly: Boot state Blinks very slowly (~0.5Hz): update in progress
4: CANopen communication (green)	Blinks when CANopen message is received	Blinks quickly: Boot state Blinks very slowly (~0.5Hz): update in progress
5: Not used (yellow) (Present only on HD67172-B2)	OFF	Blinks quickly: Boot state Blinks very slowly (~0.5Hz): update in progress

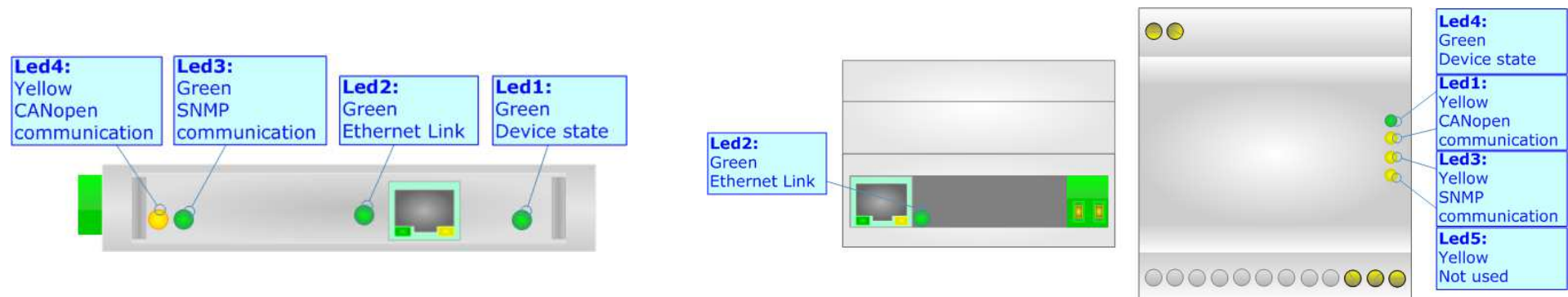

ETHERNET:

The SNMP connection and the updating of the converter must be made using Connector5 of HD67172 with at least a Category 5E cable. The maximum length of the cable should not exceed 100m. The cable has to conform to the T568 norms relative to connections in cat.5 up to 100 Mbps. To connect the device to an Hub/Switch is recommended the use of a straight cable, to connect the device to a PC/other is recommended the use of a cross cable.

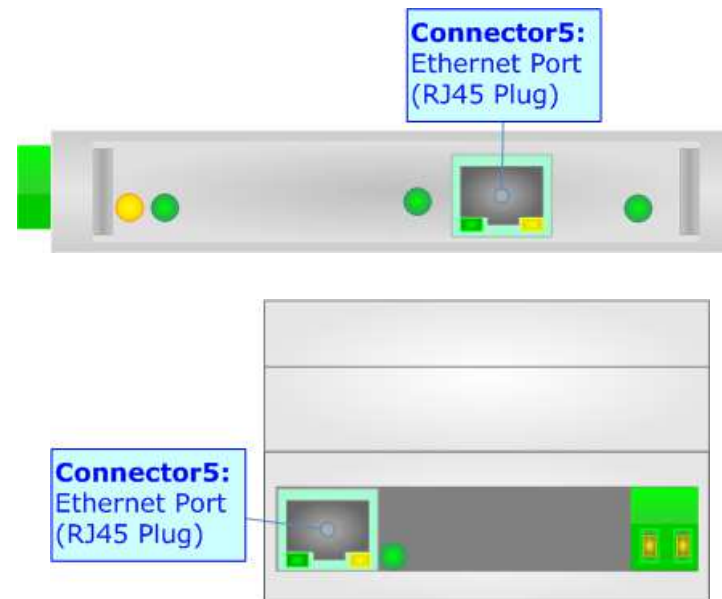

CANOPEN:

For terminating the CANopen line with a 120Ω resistor it is necessary that the Dip1 of 'Dip-Switch C' is at ON position (for the HD67172-A1) and that the Dip2 of 'Dip-Switch C' is at ON position (for the HD67172-B2).

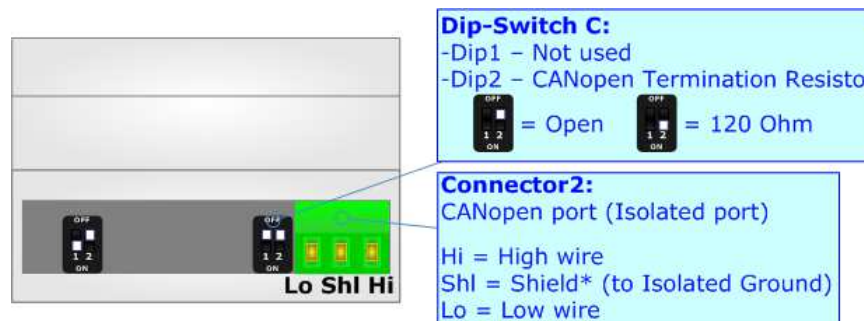
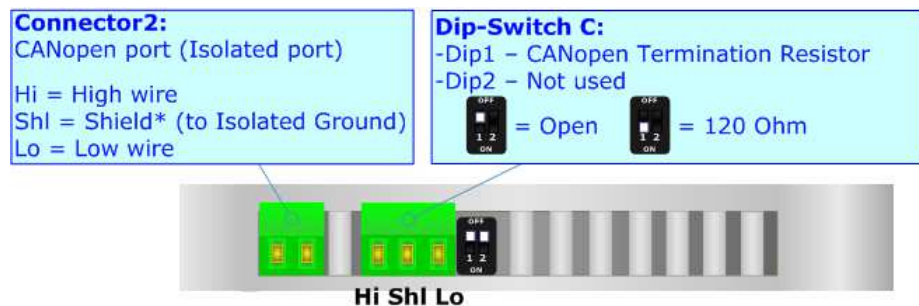

Cable characteristics:

DC parameter:	Impedance	70 Ohm/m
AC parameters:	Impedance	120 Ohm/m
	Delay	5 ns/m
Length	Baud Rate [bps]	Length MAX [m]
	10 K	5000
	20 K	2500
	50 K	1000
	100 K	650
	125 K	500
	250 K	250
	500 K	100
	800 K	50
	1000 K	25

USE OF COMPOSITOR SW67172:

To configure the Converter, use the available software that runs with Windows called SW67172. It is downloadable on the site www.adfweb.com and its operation is described in this document. *(This manual is referenced to the last version of the software present on our web site).* The software works with MSWindows (XP, Vista, Seven, 8, 10; 32/64bit).

When launching the SW67172, the window below appears (Fig. 2).



Note:

It is necessary to have installed .Net Framework 4.



Figure 2: Main window for SW67172

NEW CONFIGURATION / OPEN CONFIGURATION:

The “**New Configuration**” button creates the folder which contains the entire device’s configuration.

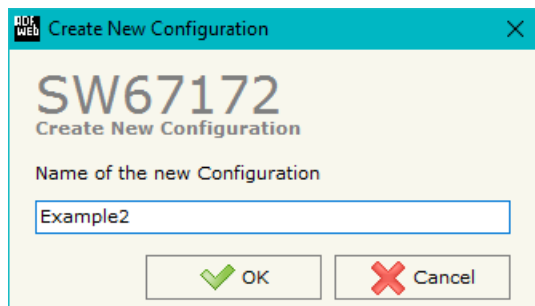

A device’s configuration can also be imported or exported:

- To clone the configurations of a Programmable “SNMP Manager / CANopen - Converter” in order to configure another device in the same manner, it is necessary to maintain the folder and all its contents;
- To clone a project in order to obtain a different version of the project, it is sufficient to duplicate the project folder with another name and open the new folder with the button “**Open Configuration**”.

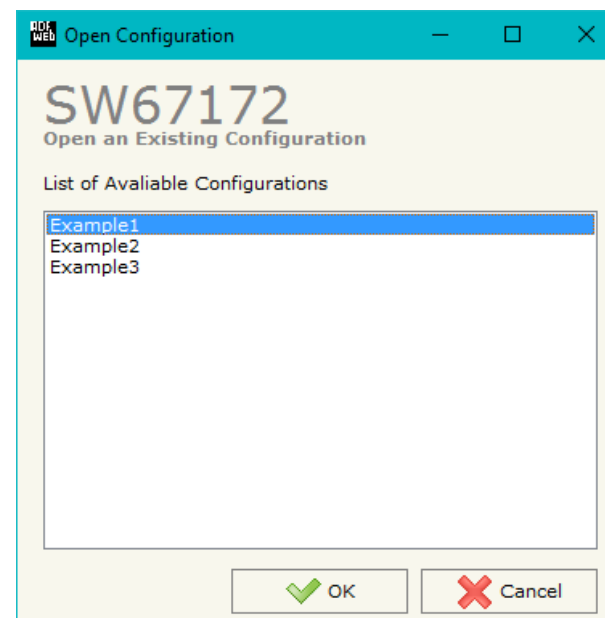

SOFTWARE OPTIONS:

By pressing the “**Settings**” () button there is the possibility to change the language of the software and check the updates for the compositor.

In the section “Language” it is possible to change the language of the software.

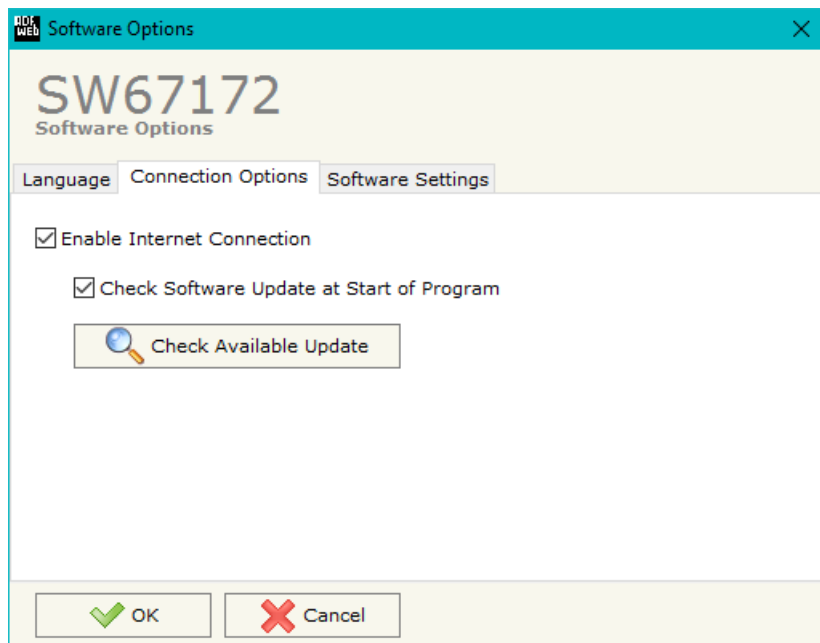

In the section “Connection Options”, it is possible to check if there are some updates of the software compositor in ADFweb.com website. Checking the option “**Check Software Update at Start of Program**”, the SW67172 check automatically if there are updates when it is launched.

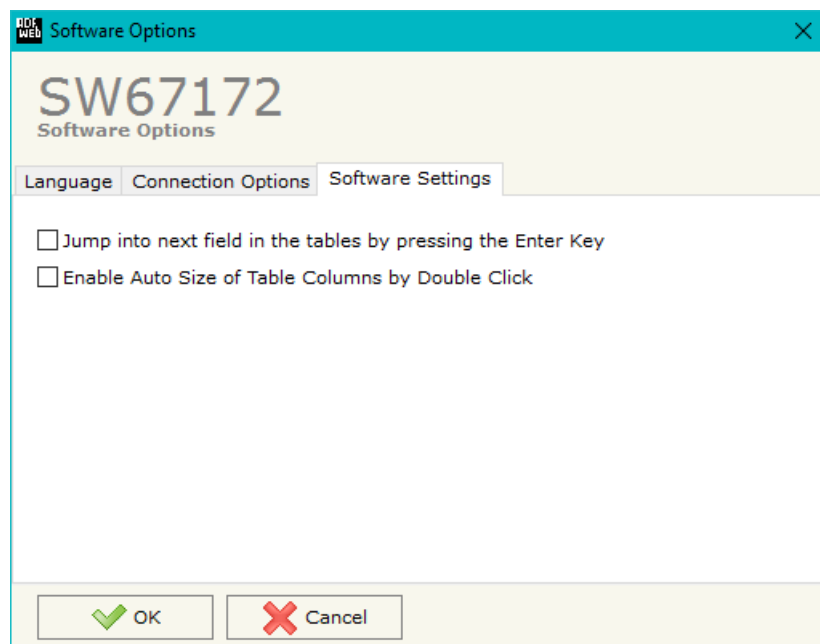

In the section "Software Settings", it is possible to enable/disable some keyboard's commands for an easier navigation inside the tables contained in the different sections of the software.

SET COMMUNICATION:

This section define the fundamental communication parameters of two buses, SNMP and CANopen.

By Pressing the **"Set Communication"** button from the main window for SW67172 (Fig. 2) the window "Set Communication" appears (Fig. 3).

The window is divided in two sections, one for the SNMP parameters and the other for the CANopen parameters.

The means of the fields for "SNMP Manager" are:

- In the field **"IP ADDRESS"** the IP address that you want to give to the SNMP side is defined;
- In the field **"SUBNET Mask"** the SubNet Mask of the SNMP side is defined;
- In the field **"GATEWAY"** the default gateway that you want to use is defined. This feature can be enabled or disabled pressing the Check Box field. This feature is used for going out of the net;
- In the field **"SNMP Name of Station"** the name of the SNMP side of the converter is defined.

The means of the fields for "CANopen" are:

- In the field **"ID Device"** the CANopen ID for the converter is defined;
- In the field **"Baudrate"** the data rate of the CANopen is defined;
- If the field **"Set Operational State at Start-up"** is checked, the state of the CANopen is defined. I.e. if it is checked the board starts in Operational State, else it starts in Pre-Operational;
- If the field **"Network Start at Start-up"** is checked, the state of the CANopen network is defined. I.e. if it is checked the board sends a command to set the Operational State of all the devices present in the network. In the field **"Delay (s)"** the delay before sending the network command for the CANopen is defined;
- In the field **"TimeOut SDO (1/10ms)"** the timeout for the SDO requests is defined;
- If the field **"Enable Sync (ms)"** is checked, the converter will generate cyclically the SYNC message with the defined delay (expressed in ms).

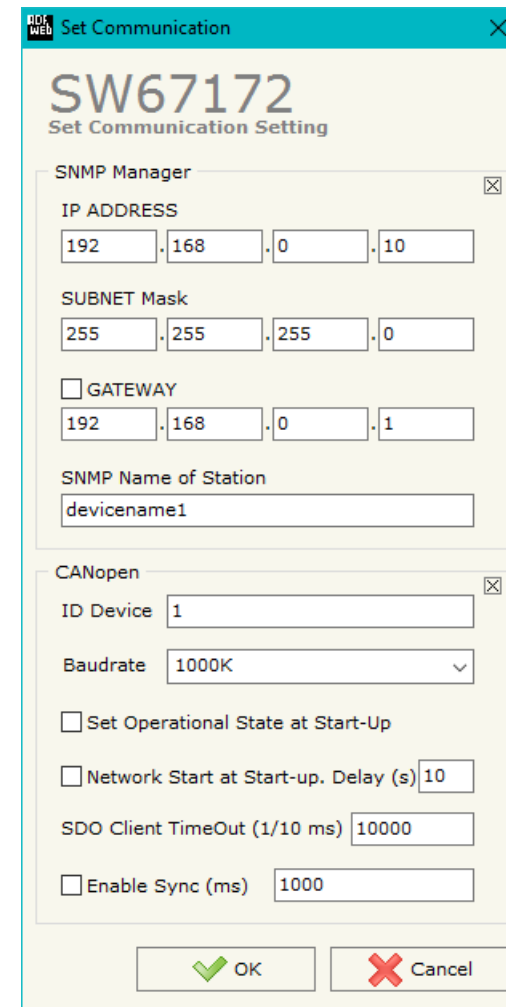

Figure 3: "Set Communication" windows

SNMP MANAGER:

N	Enable	IP Address	Version	Community Name	OID	Type	Mode	OnChange	OnCMD	OnTimer	Time	Position	Num Bytes	Conversion	Mnemonic
1	<input checked="" type="checkbox"/>	192.168.0.150	2	Public	1.3.6.1.4.1.33118.	Int	Get	<input checked="" type="checkbox"/>	<input checked="" type="checkbox"/>	<input checked="" type="checkbox"/>	1000	0	2	None	
2	<input checked="" type="checkbox"/>	192.168.0.151	1	Private	1.3.6.1.4.1.33118.	String	Trap	<input type="checkbox"/>	<input type="checkbox"/>	<input type="checkbox"/>		2	10	None	
3	<input checked="" type="checkbox"/>							<input type="checkbox"/>	<input type="checkbox"/>	<input type="checkbox"/>					
4	<input checked="" type="checkbox"/>							<input type="checkbox"/>	<input type="checkbox"/>	<input type="checkbox"/>					
5	<input checked="" type="checkbox"/>							<input type="checkbox"/>	<input type="checkbox"/>	<input type="checkbox"/>					

Figure 4: "Set SNMP Manager Access" window

By Pressing the "SNMP Manager" button from the main window for SW67172 (Fig. 2) the window "Set SNMP Manager Access" appears (Fig. 4).

The meaning of the fields in the window are the follows:

- If the field "Enable" is checked, the SNMP request is enabled;
- In the field "IP Address" the address of the SNMP Agent device that you have to read/write is defined;
- In the field "Version" the SNMP version used to send the SNMP request (1 or 2) is defined;
- In the field "Community Name" the Community Name used for the SNMP request is defined;
- In the field "OID" the OID to read/write from/to the SNMP Agent device is defined;
- In the field "Type" the type of data to read/write ('String' or 'Int') is defined;
- In the field "Mode" the type of SNMP request used ('Get', 'Set' or 'Trap') is defined;
- By checking the field "On Change" the SNMP request (only for the 'Set' Mode) is made only if CANopen data is changed;
- By checking the field "On CMD" the SNMP request is sent when the CANopen object associated to this specific SNMP request is written;
- If the field "On Timer" is checked, the SNMP request is sent cyclically;

- In the field "**Time**" the delay in ms between two SNMP requests is defined (if "On Timer" is checked);
- In the field "**Position**" it is possible to select the position where take/save the data from/to the internal SNMP array;
- In the field "**Num Bytes**" it is possible to select define the dimension of the SNMP Data;
- In the field "**Conversion**" it is possible to define the type of data conversion to apply to the read/written value;
- In the field "**Mnemonic**" a description of the data inserted in the row is defined.

**Note:**

If the field "On change" and "On Timer" is checked and the "Poll Time" is different from 0, the converter sends the SNMP writing request cyclically and also when the data is changed.

**Note:**

If the "Trap" mode is used, the fields "On CMD", "On Change" and "On Timer" must be disabled.

**Note:**

It is possible to edit manually the Community Name too.

SET SDO SERVER:

By pressing the **"Set SDO Server"** button from the main window for SW67172 (Fig. 2) the window "Set SDO Server Access" appears (Fig. 4).

This window is made to create the SDO in read or write in the CANopen side and to indicate which byte are associated to these SDOs.

It is divided in two parts, the "SDO in Read" and the "SDO in Write".

The first part is used to read, using the SDO, the data arrived from the SNMP side. The second is used to write, using SDO, the data that will be sent to the SNMP side.

The data of the columns have the following meanings:

- In the field **"Index"** the address of the SDO Object is defined;
- In the field **"SubIndex"** the second address of the SDO Object is defined;
- If the field **"N Byte"** the dimension of the SDO is defined (it can be 1, 2 or 4);
- In the field **"Address Byte1"** insert the address of the SNMP arrays where reading/writing the 1st byte of the SDO;
- In the field **"Address Byte2"** insert the address of the SNMP arrays where reading/writing the 2nd byte of the SDO (only if N Byte is 2 or 4);
- In the field **"Address Byte3"** insert the address of the SNMP arrays where reading/writing the 3rd byte of the SDO (only if N Byte is 4);
- In the field **"Address Byte4"** insert the address of the SNMP arrays where reading/writing the 4th byte of the SDO (only if N Byte is 4);
- In the field **"Mnemonic"** the description for the SDO is defined.

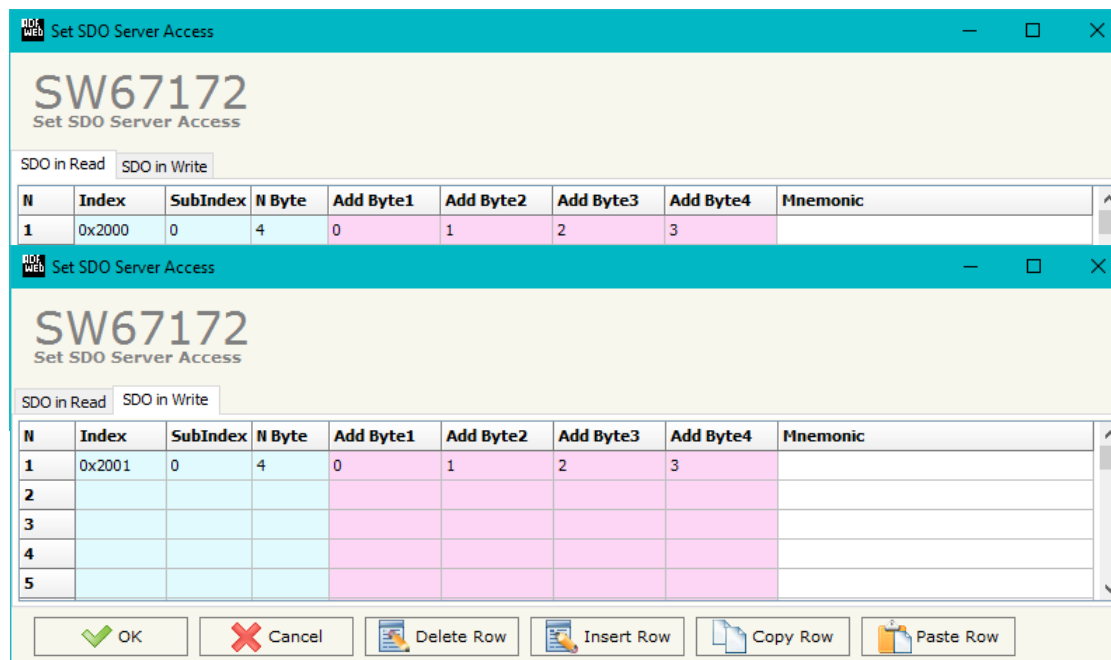

Figure 5: "Set SDO Server Access" window

SET SDO CLIENT:

By pressing the **"Set SDO Client"** button from the main window for SW67172 (Fig. 2) the window "Set SDO Client Access" appears (Fig. 6a and 6b).

With the SDO Client the HD67172 can read and/or write the data from/to others devices connected in the CANopen network.

It is divided in two parts, the "SDO Read" and the "SDO Write". The first part is used to read, using the SDO, the data in another device and then put this data in the SNMP array. The second part is used to write, using the SDO, the data present in the SNMP array to others CANopen devices.

The meaning of the columns in the "SDO Read" are:

- In the field **"Device ID"** the ID of the device to read is defined;
- In the field **"Index"** the address of the SDO to read is defined;
- In the field **"SubIndex"** the second address of the SDO to read is defined;
- In the field **"N Byte"** the dimension of the SDO to read is defined (it can be 1, 2, or 4);
- In the field **"Poll Time"** the cyclic time of the request is defined;
- In the field **"Address Byte1"** the address of the SNMP array where copying the 1st byte of the SDO read is defined;
- In the field **"Address Byte2"** the address of the SNMP array where copying the 2nd byte of the SDO read is defined (only if N Byte is 2 or 4);
- In the field **"Address Byte3"** the address of the SNMP array where copying the 3rd byte of the SDO read is defined (only if N Byte is 4);
- In the field **"Address Byte4"** the address of the SNMP array where copying the 4th byte of the SDO read is defined (only if N Byte is 4);
- In the field **"Mnemonic"** the description for the SDO is defined.

N°	ID Device	Index	SubIndex	N Byte	Poll Time	Add Byte1	Add Byte2	Add Byte3	Add Byte4	Mnemonic
1	5	0x3000	0	4	1000	0	1	2	3	
2										
3										
4										
5										

Figure 6a: "Set SDO Client Access – SDO Read" window

The meaning of the columns in the "SDO Write" are:

- In the field "**Device ID**" the ID of the device to write is defined;
- In the field "**Index**" the address for the SDO to write is defined;
- In the field "**SubIndex**" the second address for the SDO to write is defined;
- In the field "**N Byte**" the dimension of the SDO to write is defined (it can be 1, 2, or 4);
- In the field "**Poll Time**" the time to make the request is defined;
- If the field "**On Change**" is checked, the converter sends the writing request when the data from SNMP changes;
- In the field "**Address Byte1**" the address of the SNMP array where taking the 1st byte of the SDO write is defined;
- In the field "**Address Byte2**" the address of the SNMP array where taking the 2nd byte of the SDO write is defined (only if N Byte is 2 or 4);
- In the field "**Address Byte3**" the address of the SNMP array where taking the 3rd byte of the SDO write is defined (only if N Byte is 4);
- In the field "**Address Byte4**" the address of the SNMP array where taking the 4th byte of the SDO write is defined (only if N Byte is 4);
- In the field "**Mnemonic**" the description for the SDO is defined.

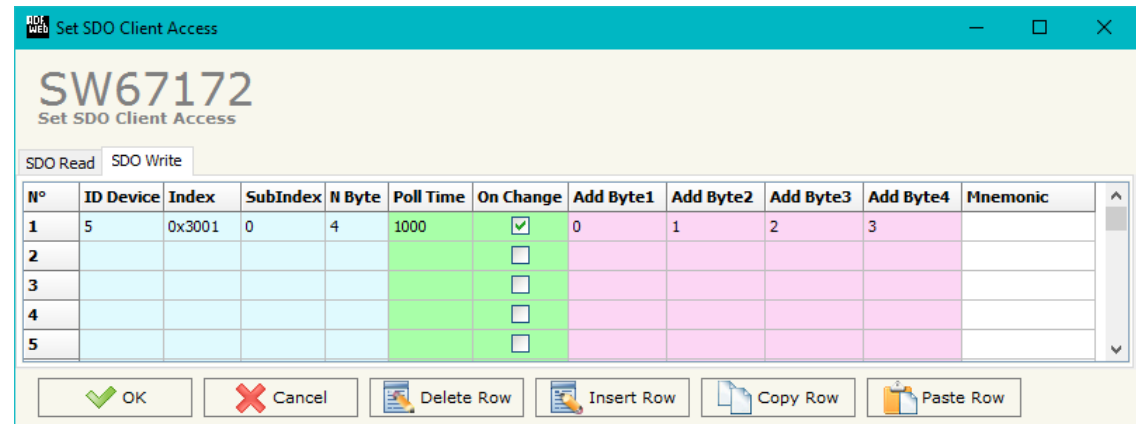

Figure 6b: "Set SDO Client Access – SDO Write" window

SET PDO ACCESS:

By pressing the "Set PDO Access" button from the main window for SW67172 (Fig. 2) the window "Set PDO Access" appears (Fig. 7a and 7b).

This window is used to create the Receive and the Transmit PDOs in the CANopen side and to indicate which bytes of SNMP side are associated to these PDOs.

It is divided in two parts, the "Receive PDO" and the "Transmit PDO". The first part is used to receive PDO from the CANopen network and copy the data in the SNMP array. The second part is used to transmit PDO in the CANopen network with the data of SNMP array.

The meaning of the columns in the "Receive PDO" are:

- In the field "**Cob-ID**" the COB-ID for the PDO is defined;
- In the field "**Dimension**" the dimension of the PDO is defined (it can be between 1 and 8 bytes);
- In the field "**Add B1**" the address of the SNMP array where coping the 1st byte of the RPDO is defined;
- In the field "**Add B2**" the address of the SNMP array where coping the 2nd byte of the RPDO is defined;
- In the field "**Add B3**" the address of the SNMP array where coping the 3rd byte of the RPDO is defined;
- In the field "**Add B4**" the address of the SNMP array where coping the 4th byte of the RPDO is defined;
- In the field "**Add B5**" the address of the SNMP array where coping the 5th byte of the RPDO is defined;
- In the field "**Add B6**" the address of the SNMP array where coping the 6th byte of the RPDO is defined;
- In the field "**Add B7**" the address of the SNMP array where coping the 7th byte of the RPDO is defined;
- In the field "**Add B8**" the address of the SNMP array where coping the 8th byte of the RPDO is defined;
- In the field "**TimeOut**" the timeout is defined. It is used to put to 0 the data into SNMP if the PDO doesn't arrive in the defined time. If the value in this field is '0', the function is not used;
- In the field "**Mnemonic**" the description for the PDO is defined.

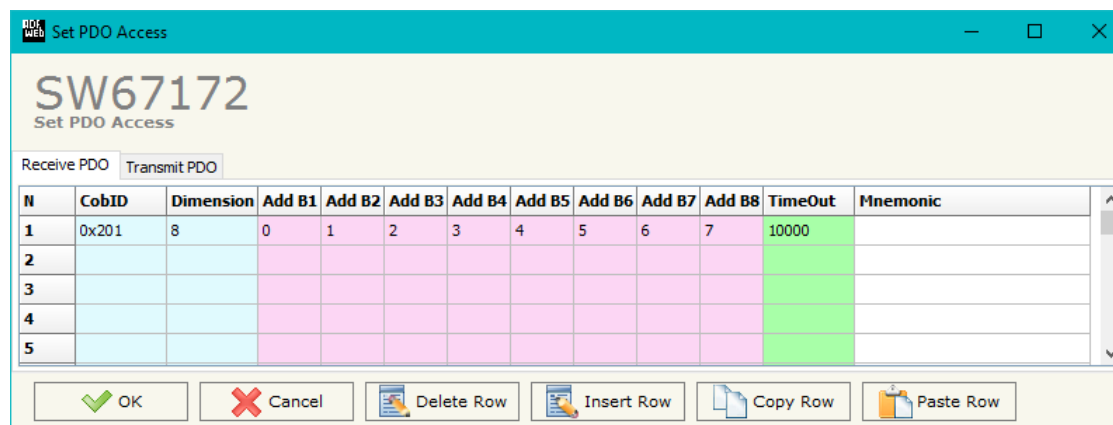
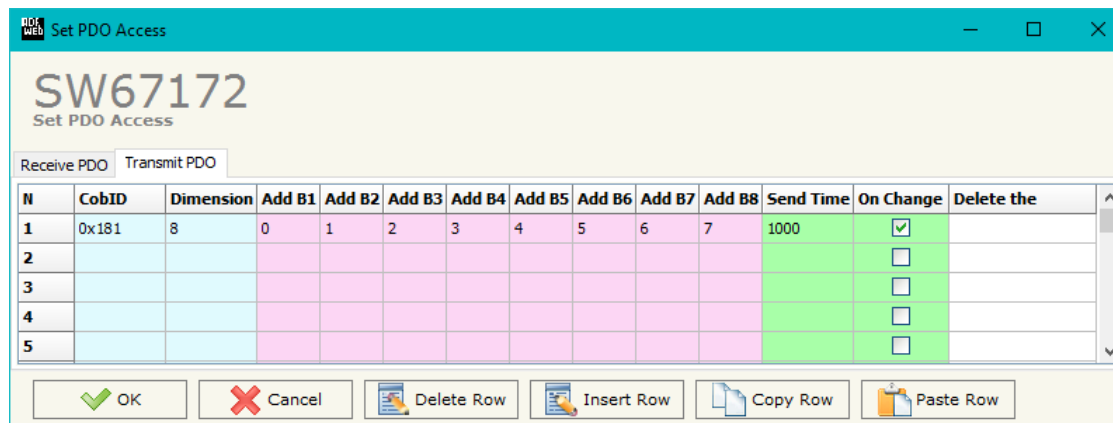

Figure 7a: "Set PDO Access – Receive PDO" window

The meaning of the columns in the "Transmit PDO" are:

- In the field "**Cob-ID**" the COB-ID for the PDO is defined;
- In the Field "**Dimension**" the dimension of the PDO is defined (it can be between 1 and 8 bytes);
- In the field "**Add B1**" the address of the SNMP array where taking the 1st byte of the TPDO is defined;
- In the field "**Add B2**" the address of the SNMP array where taking the 2nd byte of the TPDO is defined;
- In the field "**Add B3**" the address of the SNMP array where taking the 3rd byte of the TPDO is defined;
- In the field "**Add B4**" the address of the SNMP array where taking the 4th byte of the TPDO is defined;
- In the field "**Add B5**" the address of the SNMP array where taking the 5th byte of the TPDO is defined;
- In the field "**Add B6**" the address of the SNMP array where taking the 6th byte of the TPDO is defined;
- In the field "**Add B7**" the address of the SNMP array where taking the 7th byte of the TPDO is defined;
- In the field "**Add B8**" the address of the SNMP array where taking the 8th byte of the TPDO is defined;
- In the field "**Send Time**" the interval used to send the PDO is defined. The time is in milliseconds;
- If the field "**On Change**" is checked, the gateway sends the Transmit PDO when the data from SNMP change the value;
- In the field "**Mnemonic**" the description for the PDO is defined.



N	CobID	Dimension	Add B1	Add B2	Add B3	Add B4	Add B5	Add B6	Add B7	Add B8	Send Time	On Change	Delete the
1	0x181	8	0	1	2	3	4	5	6	7	1000	<input checked="" type="checkbox"/>	
2												<input type="checkbox"/>	
3												<input type="checkbox"/>	
4												<input type="checkbox"/>	
5												<input type="checkbox"/>	

Figure 7b: "Set PDO Access – Transmit PDO" window

EDS FILE:

By Pressing the "**EDS File**" button from the main window for SW67172 (Fig. 2) it is possible to generate the EDS file to be imported into the CANopen Client.

UPDATE DEVICE:

By pressing the **"Update Device"** button, it is possible to load the created Configuration into the device; and also the Firmware, if necessary.

If you don't know the actual IP address of the device you have to use this procedure:

- Turn OFF the Device;
- Put Dip1 of 'Dip-Switch A' in ON position;
- Turn on the device
- Connect the Ethernet cable;
- Insert the IP **"192.168.2.205"**;
- Select which operations you want to do;
- Press the **"Execute update firmware"** button to start the upload;
- When all the operations are "OK" turn off the Device;
- Put Dip2 of 'Dip-Switch A' at OFF position;
- Turn ON the device.

If you know the actual IP address of the device, you have to use this procedure:

- Turn on the Device with the Ethernet cable inserted;
- Insert the actual IP of the Converter;
- Select which operations you want to do;
- Press the **"Execute update firmware"** button to start the upload;
- When all the operations are "OK" the device automatically goes at Normal Mode.

At this point the configuration/firmware on the device is correctly update.

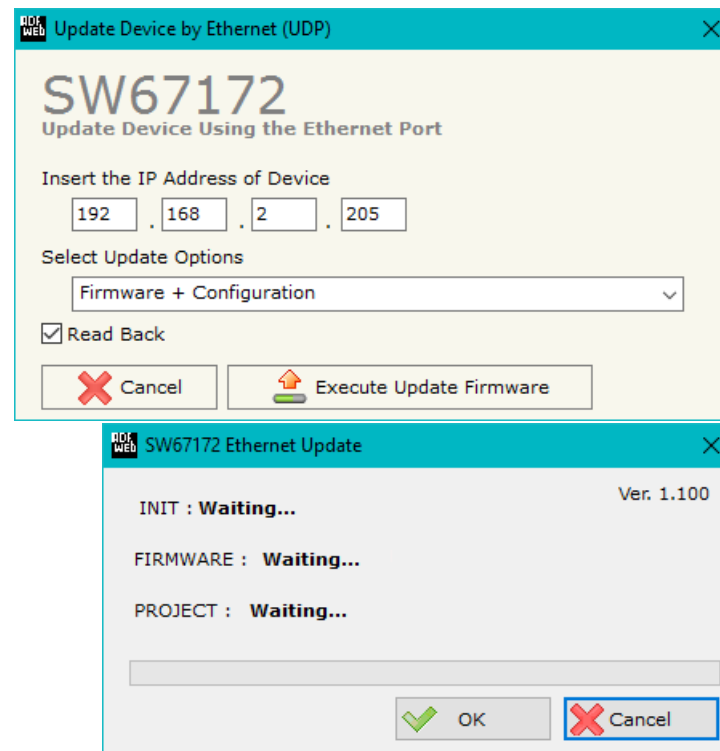





Figure 8: "Update device" windows

 **Note:**
When you install a new version of the software, if it is the first time it is better you do the update of the Firmware in the HD67172 device.

 **Note:**
When you receive the device, for the first time, you also have to update the Firmware in the HD67172 device.

 **Warning:**
If Fig. 9 appears when you try to do the Update try these points before seeking assistance:

- Try to repeat the operations for the updating;
- Try with another PC;
- Try to restart the PC;
- If you are using the program inside a Virtual Machine, try to use in the main Operating System;
- If you are using Windows Seven or Vista or 8 or 10, make sure that you have the administrator privileges;
- Take attention at Firewall lock;
- In case you have to program more than one device, using the "UDP Update", you have to cancel the ARP table every time you connect a new device on Ethernet. For do this you have to launch the "Command Prompt" and write the command "arp -d". Pay attention that with Windows Vista, Seven, 8 you have to launch the "Command Prompt" with Administrator Rights;
- Check the LAN settings.

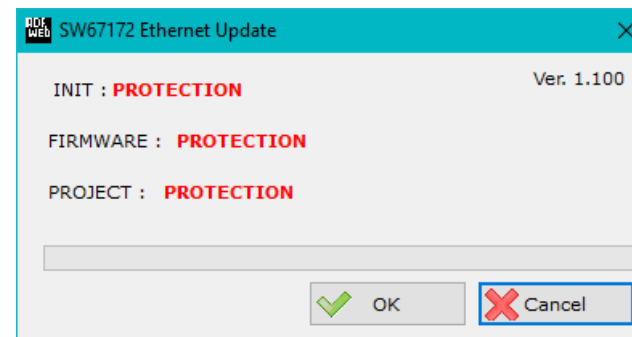

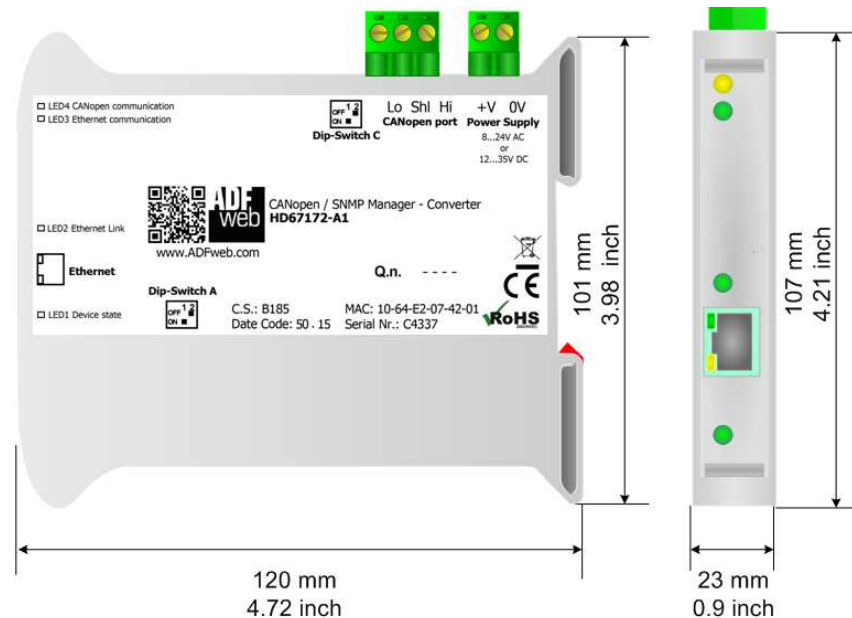

Figure 9: "Protection" window

 In the case of HD67172 you have to use the software "SW67172": www.adfweb.com/download/filefold/SW67172.zip.

MECHANICAL DIMENSIONS:



Housing: PVC
Weight: 200g (Approx)

Figure 10a: Mechanical dimensions scheme for HD67172-A1

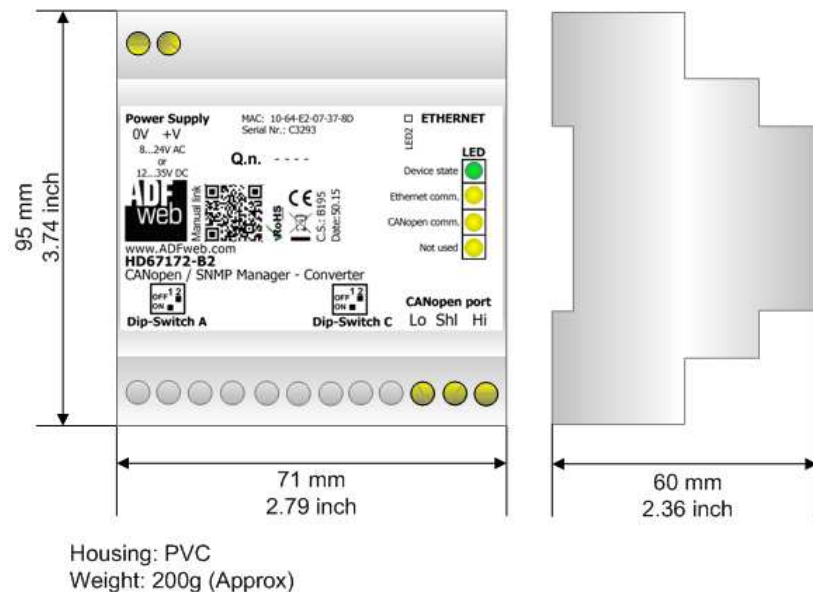

Housing: PVC
Weight: 200g (Approx)

Figure 10b: Mechanical dimensions scheme for HD67172-B2

ORDERING INFORMATIONS:

The ordering part number is formed by a valid combination of the following:

HD67172 - x x

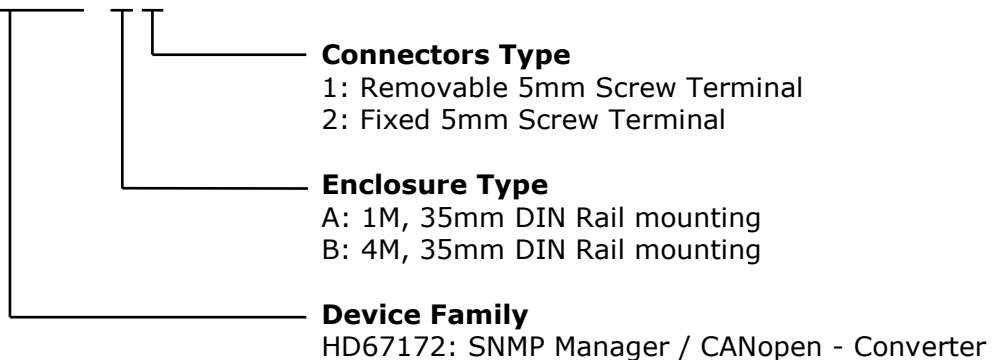

Order Code: **HD67172-A1** - SNMP Manager / CANopen - Converter

Order Code: **HD67172-B2** - SNMP Manager / CANopen - Converter

ACCESSORIES:

Order Code: **AC34001** - 35mm Rail DIN - Power Supply 220/240V AC 50/60Hz - 12 V AC

Order Code: **AC34002** - 35mm Rail DIN - Power Supply 110V AC 50/60Hz - 12 V AC

DISCLAIMER:

All technical content within this document can be modified without notice. The content of the document is a under continual renewal. For losses due to fire, earthquake, third party access or other accidents, or intentional or accidental abuse, misuse, or use under abnormal conditions repairs are charged to the user. ADFweb.com S.r.l. will not be liable for accidental loss of use or inability to use this product, such as loss of business income. ADFweb.com S.r.l. shall not be liable for consequences of improper use.

OTHER REGULATIONS AND STANDARDS:**WEEE INFORMATION**

Disposal of old electrical and electronic equipment (as in the European Union and other European countries with separate collection systems).

— This symbol on the product or on its packaging indicates that this product may not be treated as household rubbish. Instead, it should be taken to an applicable collection point for the recycling of electrical and electronic equipment. If the product is disposed correctly, you will help prevent potential negative environmental factors and impact of human health, which could otherwise be caused by inappropriate disposal. The recycling of materials will help to conserve natural resources. For more information about recycling this product, please contact your local city office, your household waste disposal service or the shop where you purchased the product.

RESTRICTION OF HAZARDOUS SUBSTANCES DIRECTIVE

The device respects the 2002/95/EC Directive on the restriction of the use of certain hazardous substances in electrical and electronic equipment (commonly referred to as Restriction of Hazardous Substances Directive or RoHS).

CE MARKING

The product conforms with the essential requirements of the applicable EC directives.

WARRANTIES AND TECHNICAL SUPPORT:

For fast and easy technical support for your ADFweb.com SRL products, consult our internet support at www.adfweb.com. Otherwise contact us at the address support@adfweb.com

RETURN POLICY:

If while using your product you have any problem and you wish to exchange or repair it, please do the following:

- Obtain a Product Return Number (PRN) from our internet support at www.adfweb.com. Together with the request, you need to provide detailed information about the problem.
- Send the product to the address provided with the PRN, having prepaid the shipping costs (shipment costs billed to us will not be accepted).

If the product is within the warranty of twelve months, it will be repaired or exchanged and returned within three weeks. If the product is no longer under warranty, you will receive a repair estimate.



ADFweb.com S.r.l.
Via Strada Nuova, 17
IT-31010 Mareno di Piave
TREVISO (Italy)
Phone +39.0438.30.91.31
Fax +39.0438.49.20.99
www.adfweb.com

