

## User Manual

Revision 1.004  
English

### PROFINET / Serial - Converter

(Order Code: HD67601-232-A1, HD67601-485-A1,  
HD67601-422-A1)

#### Benefits and Main Features:

- ✦ Very easy to configure
- ✦ Triple electrical isolation
- ✦ Two PROFINET ports
- ✦ Temperature range: -40°C/+85°C (-40°F/+185°F)



**INDEX:**

	Page
INDEX	2
UPDATED DOCUMENTATION	2
REVISION LIST	2
WARNING	2
TRADEMARKS	2
SECURITY ALERT	3
EXAMPLE OF CONNECTION	4
CONNECTION SCHEME	5
CHARACTERISTICS	8
CONFIGURATION	8
POWER SUPPLY	9
FUNCTION MODES	10
LEDS	11
PROFINET	12
RS232	13
RS485	13
RS422	14
USE OF COMPOSITOR SW67601	15
NEW PROJECT / OPEN PROJECT	16
SOFTWARE OPTIONS	17
SET COMMUNICATION	18
XML FILE	19
UPDATE DEVICE	20
SERIAL PROTOCOL	22
MECHANICAL DIMENSIONS	24
PLC CONFIGURATION	25
ORDERING INFORMATIONS	28
ACCESSORIES	28
PLC CONFIGURATION	29
DISCLAIMER	29
OTHER REGULATIONS AND STANDARDS	29
WARRANTIES AND TECHNICAL SUPPORT	30
RETURN POLICY	30

**UPDATED DOCUMENTATION:**

Dear customer, we thank you for your attention and we remind you that you need to check that the following document is:

- Updated
- Related to the product you own

To obtain the most recently updated document, note the “document code” that appears at the top right-hand corner of each page of this document.

With this “Document Code” go to web page [www.adfweb.com/download/](http://www.adfweb.com/download/) and search for the corresponding code on the page. Click on the proper “Document Code” and download the updates.

**REVISION LIST:**

Revision	Date	Author	Chapter	Description
1.001	15/05/2013	Fl	All	Revision
1.002	08/10/2013	Fl	All	Revision
1.003	11/12/2013	Fl	All	Revision
1.004	21/12/2018	Ff	All	Added RS422 version

**WARNING:**

ADFweb.com reserves the right to change information in this manual about our product without warning.  
ADFweb.com is not responsible for any error this manual may contain.

**TRADEMARKS:**

All trademarks mentioned in this document belong to their respective owners.

**SECURITY ALERT:****GENERAL INFORMATION**

To ensure safe operation, the device must be operated according to the instructions in the manual. When using the device, legal and safety regulation are required for each individual application. The same applies also when using accessories.

**INTENDED USE**

Machines and systems must be designed so the faulty conditions do not lead to a dangerous situation for the operator (i.e. independent limit switches, mechanical interlocks, etc.).

**QUALIFIED PERSONNEL**

The device can be used only by qualified personnel, strictly in accordance with the specifications.

Qualified personnel are persons who are familiar with the installation, assembly, commissioning and operation of this equipment and who have appropriate qualifications for their job.

**RESIDUAL RISKS**

The device is state-of-the-art and is safe. The instruments can represent a potential hazard if they are inappropriately installed and operated by untrained personnel. These instructions refer to residual risks with the following symbol:



This symbol indicates that non-observance of the safety instructions is a danger for people that could lead to serious injury or death and / or the possibility of damage.

**CE CONFORMITY** or give us a call if you need it.

**EXAMPLE OF CONNECTION:**

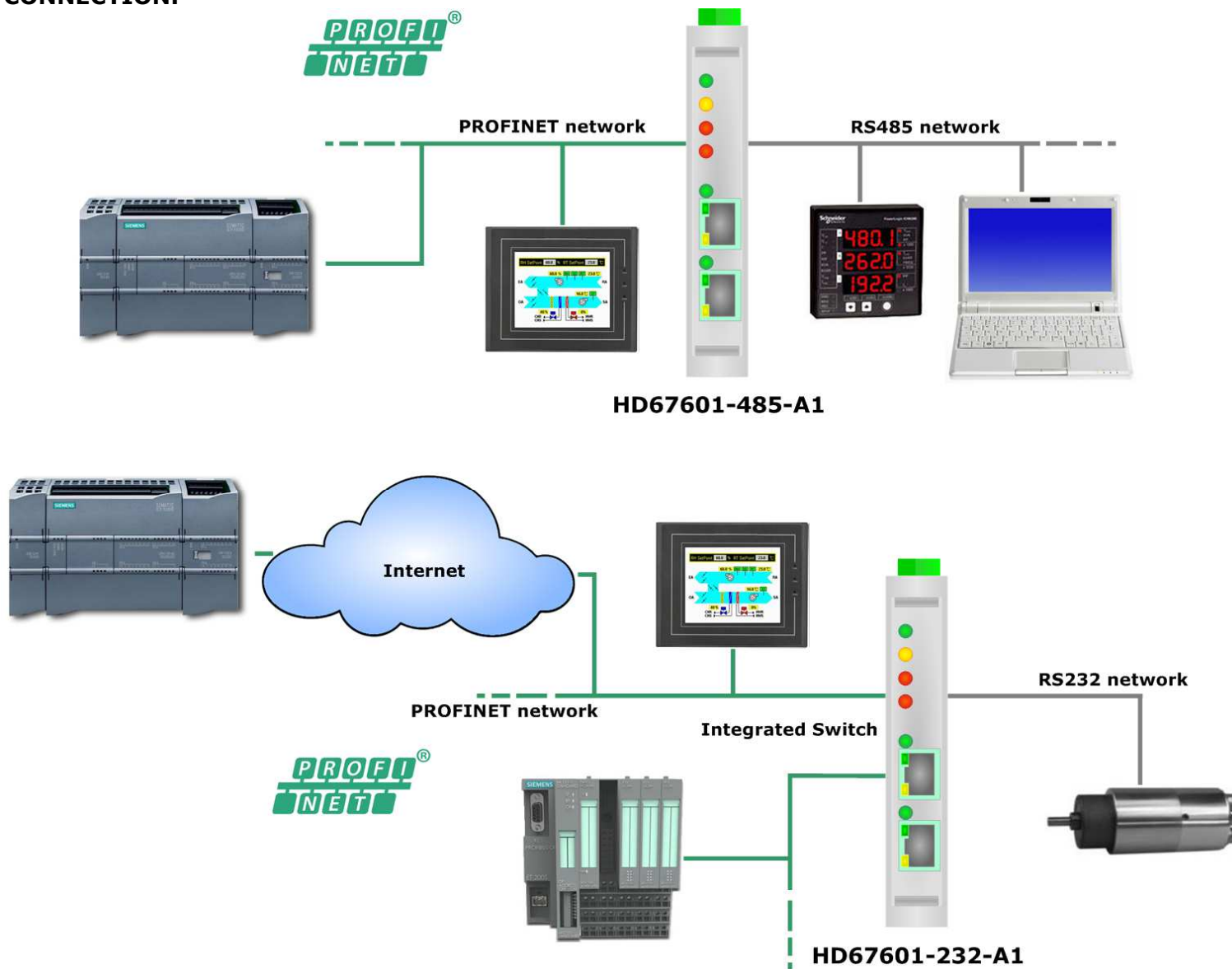

**CONNECTION SCHEME:**

**Dip-Switch A:**  
 -Dip1 – Must be at ON  
 -Dip2 – Functioning Mode

= Normal = Boot

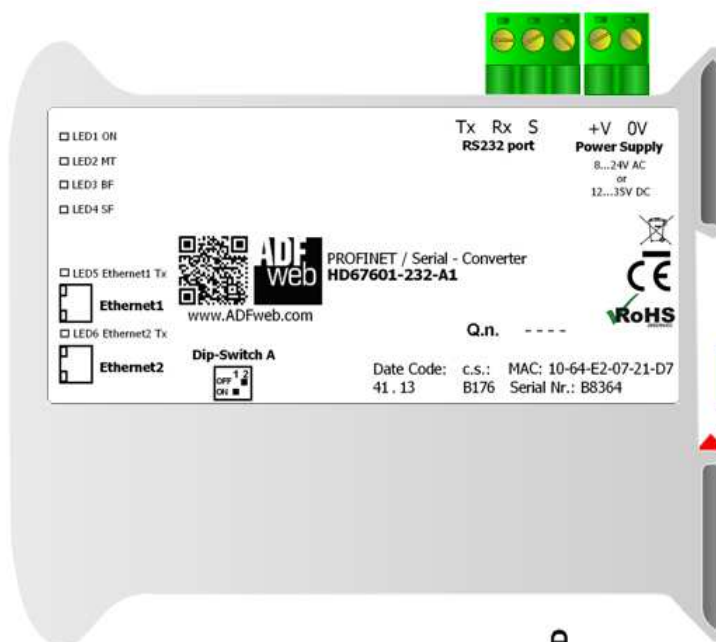

**Led1:** Green ON

**Led2:** Yellow MT

**Led3:** Red BF

**Led4:** Red SF

**Led5:** Green Ethernet1 Tx

**Connector3:** Ethernet1 port (RJ45 Plug)

**Led6:** Green Ethernet2 Tx

**Connector4:** Ethernet2 port (RJ45 Plug)

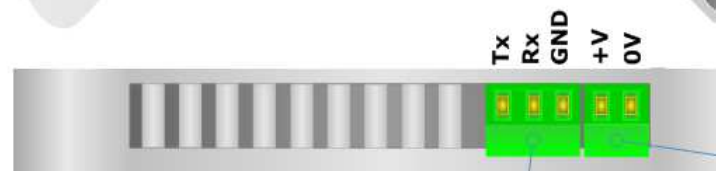

**Connector2:**  
 RS232 (Isolated port)

GND = Ground\* (to Isolated Ground)  
 Rx = Rx line  
 Tx = Tx line

**Connector1:**  
 Power Supply port

0V = Ground  
 +V = Positive wire

V AC: min 8V ; max 24V  
 V DC: min 12V ; max 35V

Figure 1a: Connection scheme for HD67601-232-A1

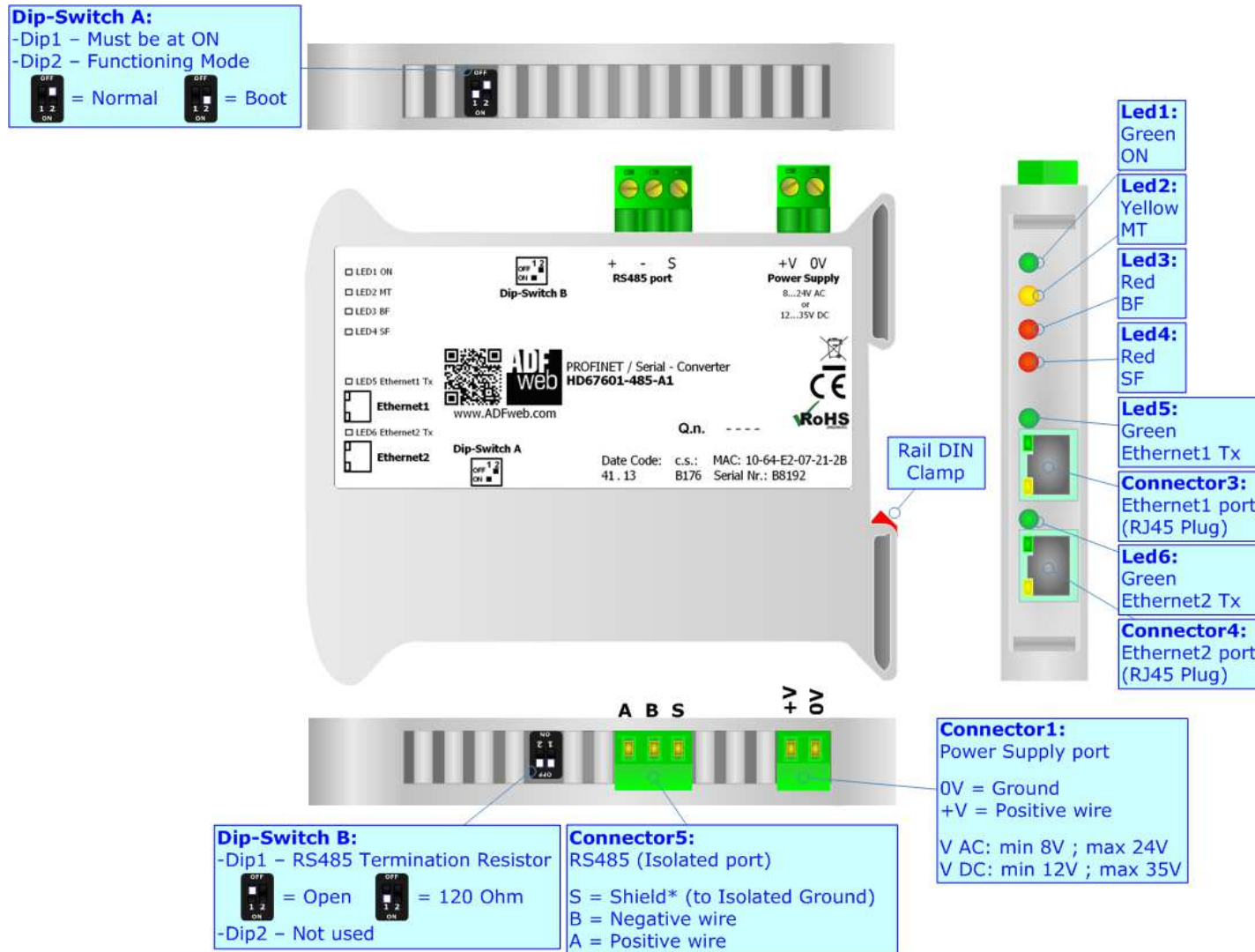

Figure 1b: Connection scheme for HD67601-485-A1

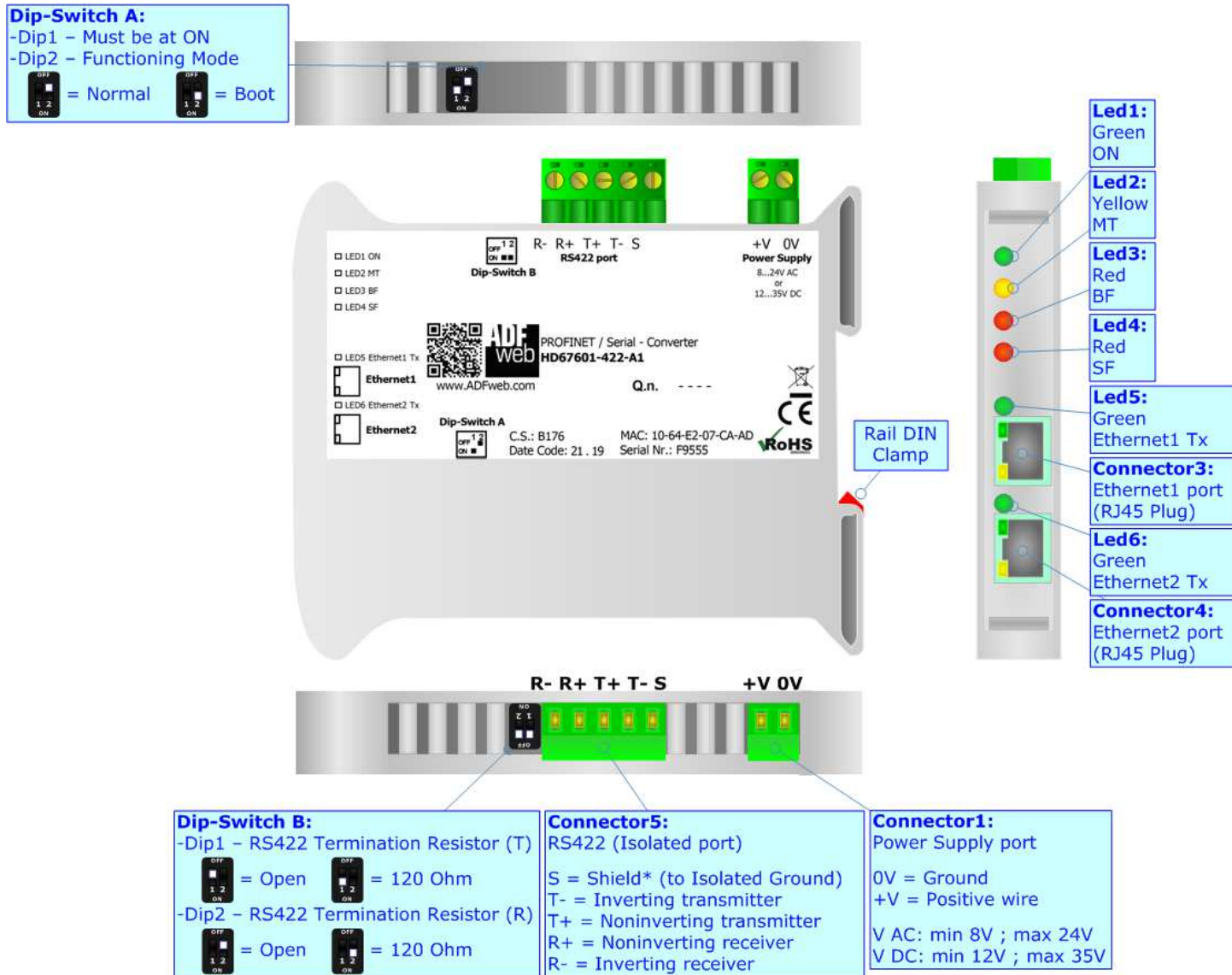

Figure 1c: Connection scheme for HD67601-422-A1



**CHARACTERISTICS:**

The HD67601 is a PROFINET / Serial Converter.

It allows for the following characteristics:

- Up to 498 bytes in reading and 498 bytes in writing;
- Triple isolation between Serial - Power Supply, Serial - Ethernet, Power Supply - Ethernet.
- Two-directional information between Serial and PROFINET;
- Mountable on 35mm Rail DIN;
- Wide power supply input range: 8...24V AC or 12...35V DC;
- Wide temperature range: -40°C / 85°C [-40°F / +185°F].

**CONFIGURATION:**



You need Compositor SW67601 software on your PC in order to perform the following:

- Define the parameters of PROFINET line;
- Define the parameters of Serial line;
- Generate the XML file to be imported on the master PROFINET;
- Update the device.



**POWER SUPPLY:**

The devices can be powered at 8...24V AC and 12...35V DC. For more details see the two tables below.

VAC 		VDC 	
Vmin	Vmax	Vmin	Vmax
8V	24V	12V	35V

Consumption at 24V DC:

Device	Consumption [W/VA]
HD67601-232-A1	3.5
HD67601-485-A1	3.5
HD67601-422-A1	3.5

**Connector1:**  
Power Supply port  
0V = Ground  
+V = Positive wire  
V AC: min 8V ; max 24V  
V DC: min 12V ; max 35V

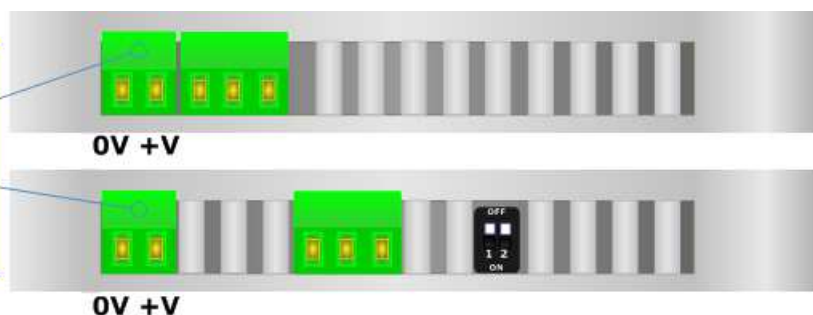

**Caution: Do not reverse the polarity power**

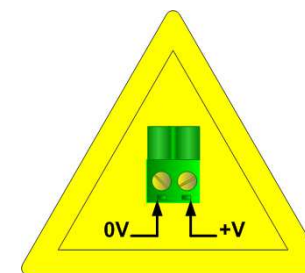

HD67601-xxx-A1

**FUNCTION MODES:**

The device has got two function modes depending on the position of the 'Dip2 of Dip-Switch A':

- The first, with 'Dip2 of Dip-Switch A' at "OFF" position, is used for the normal working of the device.
- The second, with 'Dip2 of Dip-Switch A' at "ON" position, is used for uploading the Project and/or Firmware.

For the operations to follow for the updating, see 'UPDATE DEVICE' section.

According to the functioning mode, the LEDs will have specific functions, see 'LEDS' section.

**Warning:**

Dip1 of 'Dip-Switch A' must be at ON position to work even if the Ethernet cable is not inserted.

**LEDS:**

The device has got six LEDs that are used to give information about the functioning status. The various meanings of the LEDs are described in the table below.

LED	Normal Mode	Boot Mode
1: ON [supply voltage ] (green)	<b>ON:</b> Device powered <b>OFF:</b> Device not powered	<b>ON:</b> Device powered <b>OFF:</b> Device not powered
2: MT [maintenance display] (yellow)	<b>ON:</b> Maintenance problem is present <b>OFF:</b> No maintenance problems are present	<b>Blinks quickly:</b> Boot state <b>Blinks very slowly (~0.5Hz):</b> update in progress
3: BF [bus fault] (red)	<b>ON:</b> The Ethernet connection is defective; the IP address exists several times in the network; the own NameOfStation exists several times in the network; no IP address has been set <b>Flashing:</b> At least one configured AR is no longer in the data exchange <b>OFF:</b> No errors are present	<b>Blinks quickly:</b> Boot state <b>Blinks very slowly (~0.5Hz):</b> update in progress
4: SF [group error] (red)	<b>ON:</b> At least one AR is not in the data exchange <b>OFF:</b> No errors are present	<b>Blinks quickly:</b> Boot state <b>Blinks very slowly (~0.5Hz):</b> update in progress
5: Ethernet1 Tx (green)	Blinks when Ethernet frames are transmitted	<b>Blinks quickly:</b> Boot state <b>Blinks very slowly (~0.5Hz):</b> update in progress
6: Ethernet2 Tx (green)	Blinks when Ethernet frames are transmitted	<b>Blinks quickly:</b> Boot state <b>Blinks very slowly (~0.5Hz):</b> update in progress

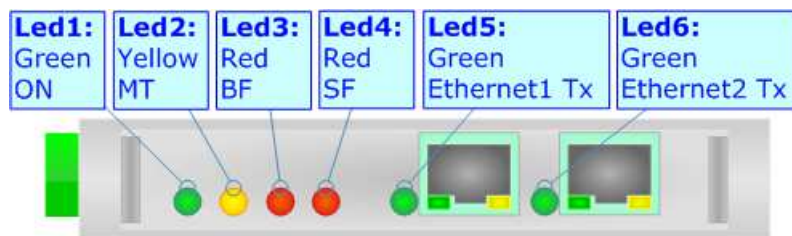

**PROFINET:**

The PROFINET connection must be made using Connector3 and/or Connector4 of HD67601-xxx-A1 with at least a Category 5E cable. The maximum length of the cable should not exceed 100m. The cable has to conform to the T568 norms relative to connections in cat.5 up to 100 Mbps. To connect the device to a Hub/Switch the use of a straight cable is recommended. To connect the device to a PC/PLC/other the use of a cross cable is recommended.

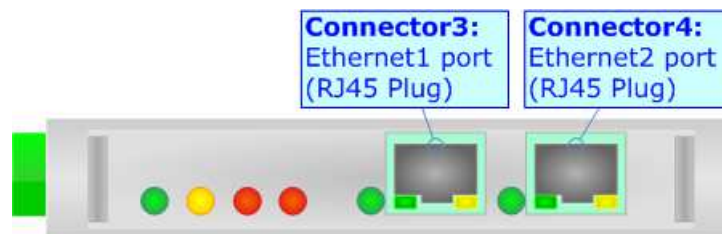

**RS232:**

The connection from a RS232 socket to a serial port (example one from a personal computer) must be made with a NULL MODEM cable (a serial cable where the pins 2 and 3 are crossed). It is recommended that the RS232 cable not exceed 15 meters.

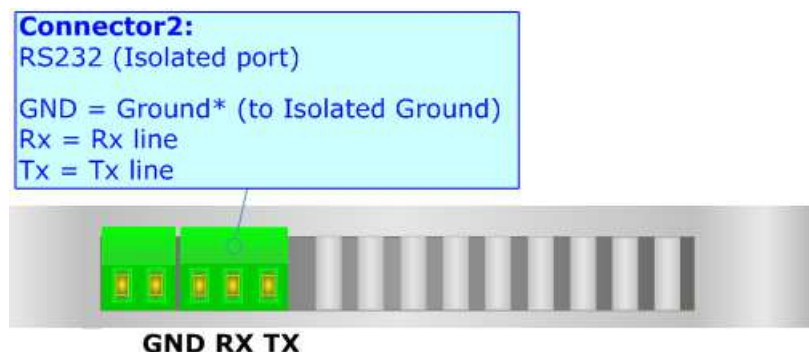

**RS485:**

To terminate the RS485 line with a 120Ω resistor, it is necessary to put dip 1 ON, like in figure.

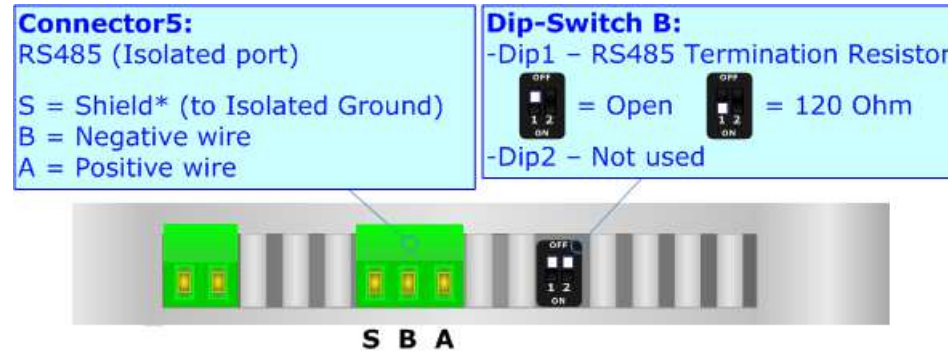

The maximum length of the cable should be 1200m (4000 feet).

Here some codes of cables:

- Belden: p/n 8132 - 2x 28AWG stranded twisted pairs conductor + foil shield + braid shield;
- Belden p/n 82842 - 2x 24AWG stranded twisted pairs conductor + foil shield + braid shield;
- Tasker: p/n C521 - 1x 24AWG twisted pair conductor + foil shield + braid shield;
- Tasker: p/n C522 - 2x 24AWG twisted pairs conductor + foil shield + braid shield.

**RS422:**

For terminate the RS485 line with a 120Ω resistor it is necessary to put ON dip 1 for T line and/or put ON dip 2 for R line, like in figure.

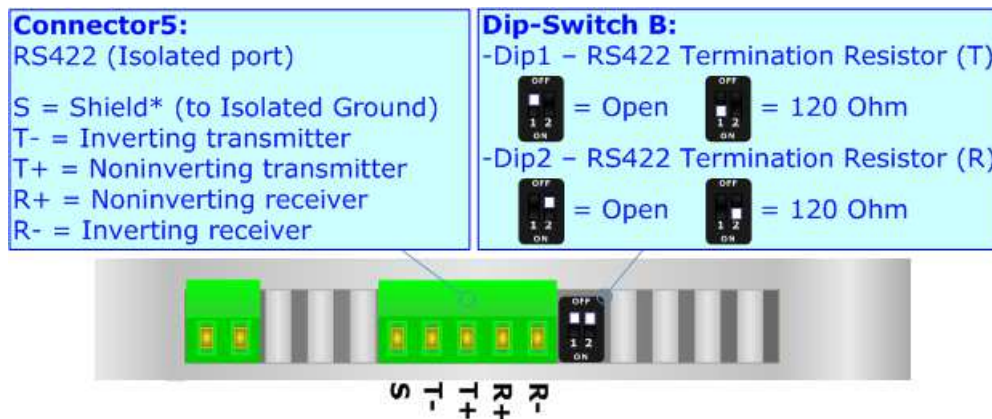

The maximum length of the cable should be 1200m (4000 feet).

**USE OF COMPOSITOR SW67601:**

To configure the Converter, use the available software that runs with Windows called SW67601. It is downloadable from the site [www.adfweb.com](http://www.adfweb.com) and its operation is described in this document (*this manual is referenced to the last version of the software present on our web site*). The software works with MSWindows (XP, Vista, Seven, 8, 10; 32/64bit).

When launching the SW67601, the window below appears (Fig. 2).

**Note:**

It is necessary to have installed .Net Framework 4.

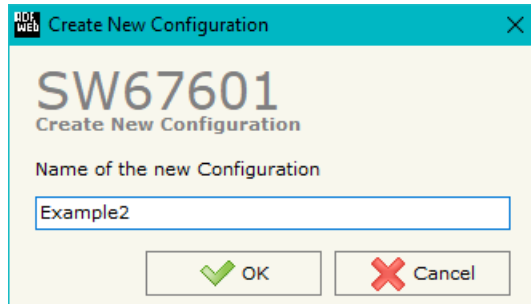

Figure 2: Main window for SW67601



**NEW CONFIGURATION / OPEN CONFIGURATION:**

The “**New Configuration**” button creates the folder which contains the entire device’s configuration.



A device’s configuration can also be imported or exported:

- To clone the configurations of a Programmable “PROFINET / Serial - Converter” in order to configure another device in the same manner, it is necessary to maintain the folder and all its contents;
- To clone a project in order to obtain a different version of the project, it is sufficient to duplicate the project folder with another name and open the new folder with the button “**Open Configuration**”.

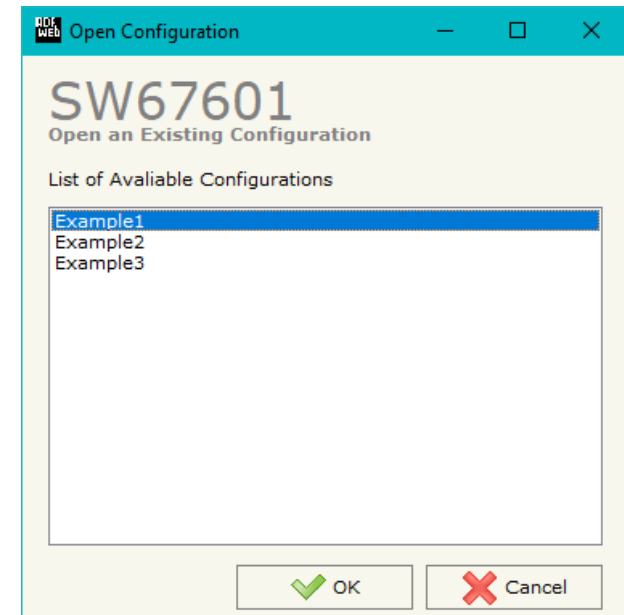

**SOFTWARE OPTIONS:**

By pressing the “**Settings**” () button there is the possibility to change the language of the software and check the updatings for the compositor.

In the section “Language” it is possible to change the language of the software.

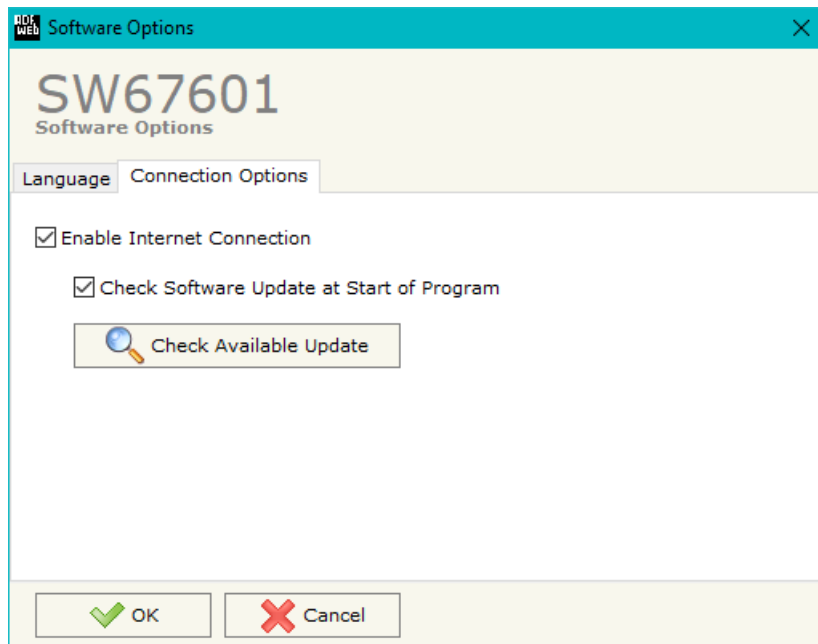

In the section “Connection Options”, it is possible to check if there are some updatings of the software compositor in ADFweb.com website. Checking the option “**Check Software Update at Start of Program**”, the SW67601 check automatically if there are updatings when it is launched.

## SET COMMUNICATION:

This section defines the fundamental communication parameters of two buses, PROFINET and Serial.

By Pressing the **"Set Communication"** button from the main window for SW67601 (Fig. 2), the window "Set Communication" appears (Fig. 3).

The window is divided in two sections, one for the PROFINET and the other for the Serial.

The meanings of the fields for "PROFINET" are:

- In the field **"IP ADDRESS"** the IP address of the converter is defined;
- In the fields **"SUBNET Mask"** the SubNet Mask of the converter is defined;
- In the fields **"GATEWAY"** the default gateway of the network is defined. This feature can be enabled or disabled pressing the Check Box field. This feature is used for going out of the net;
- In the field **"Port"** the port used for PROFINET communication is defined. The port has a fixed value of 34964;
- In the field **"PROFINET Name of Station"** it is possible to assign a name to the PROFINET node;
- In the fields **"Number Byte IN"** the number of input byte of the converter is defined;
- In the fields **"Number Byte Out"** the number of output byte of the converter is defined.

The meanings of the fields for the "Serial" section are:

- In the field **"Serial"** the serial to use is defined;
- In the field **"Baudrate"** the baudrate for the serial line is defined;
- In the field **"Parity"** the parity of the serial line is defined.



### Note:

In the fields **"Number Byte IN"** and **"Number Byte Out"** insert the number of maximum bytes that are sent/received plus 2. The value can be a maximum of 500 (498 data bytes + 2 fixed).

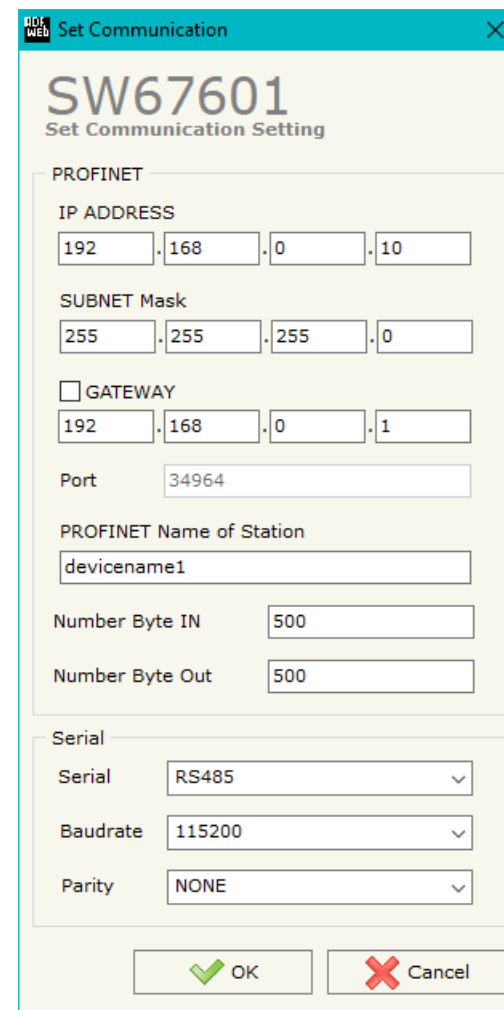

Figure 3: "Set Communication" window

**XML FILE:**

By Pressing the "**PROFINET XML**" button from the main window for SW67601 (Fig. 2) it is possible to generate the xml file to be imported into the master PROFINET.

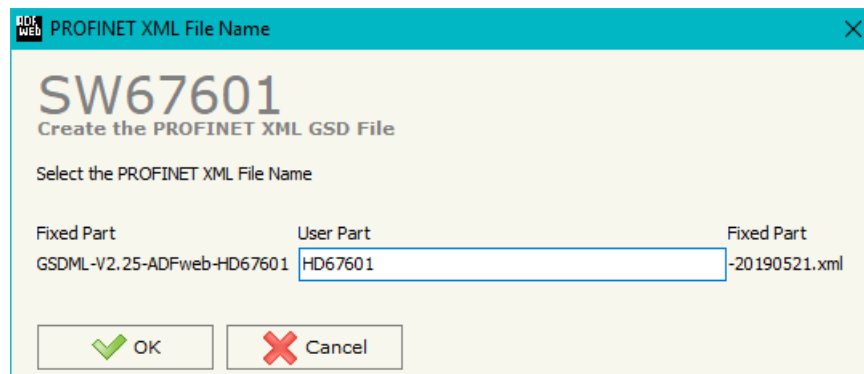

Figure 4: "PROFINET XML File Name" window

**UPDATE DEVICE:**

By pressing the **"Update Device"** button, it is possible to load the created Configuration into the device; and also the Firmware, if necessary.

If you don't know the actual IP address of the device you have to use this procedure:

- Turn off the Device;
- Put Dip1 of 'Dip-Switch A' at ON position;
- Turn on the device
- Connect the Ethernet cable;
- Insert the IP **"192.168.2.205"**;
- Press the **"Ping"** button, "Device Found!" must appear";
- Press the **"Next"** button;
- Select which operations you want to do;
- Press the **"Execute update firmware"** button to start the upload;
- When all the operations are "OK" turn off the Device;
- Put Dip1 of 'Dip-Switch A' at OFF position;
- Turn on the device.

If you know the actual IP address of the device you have to use this procedure:

- Turn on the Device with the Ethernet cable inserted;
- Insert the actual IP of the Converter;
- Press the **"Ping"** button, must appear "Device Found!";
- Press the **"Next"** button;
- Select which operations you want to do;
- Press the **"Execute update firmware"** button to start the upload;
- When all the operations are "OK" the device automatically goes at Normal Mode.

At this point the configuration/firmware on the device is correctly updated.

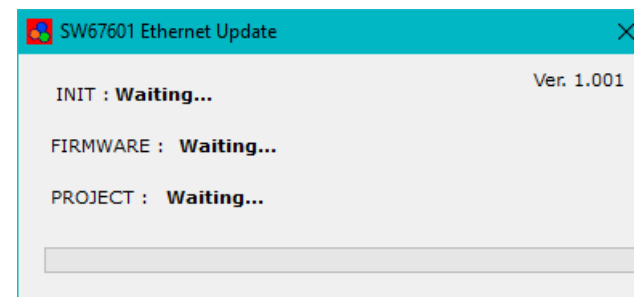
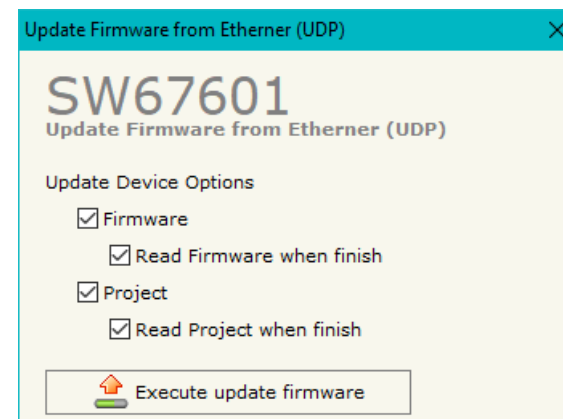
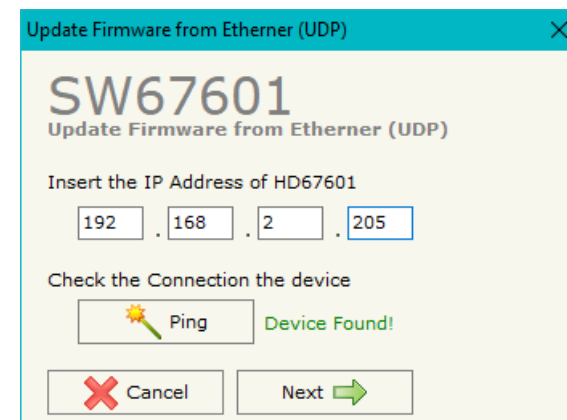

Figure 5: "Update device" windows

**Note:**

When you install a new version of the software, if it is the first time it is better you do the update of the Firmware in the HD67601 device.

**Note:**

When you receive the device, for the first time, you also have to update the Firmware in the HD67601 device.

**Warning:**

If Fig. 6 appears when you try to do the Update try these points before seeking assistance:

- Try to repeat the operations for the updating;
- Try with another PC;
- Try to restart the PC;
- Check the LAN settings;
- Check the Wi-Fi settings;
- If you are using the program inside a Virtual Machine, try to use in the main Operating System;
- If you are using Windows Seven, Vista, 8 or 10 make sure that you have the administrator privileges;
- In case you have to program more than one device, using the "UDP Update", you have to cancel the ARP table every time you connect a new device on Ethernet. For do this you have to launch the "Command Prompt" and write the command "arp -d". Pay attention that with Windows Vista, Seven, 8, 10 you have to launch the "Command Prompt" with Administrator Rights;
- Pay attention at Firewall lock.

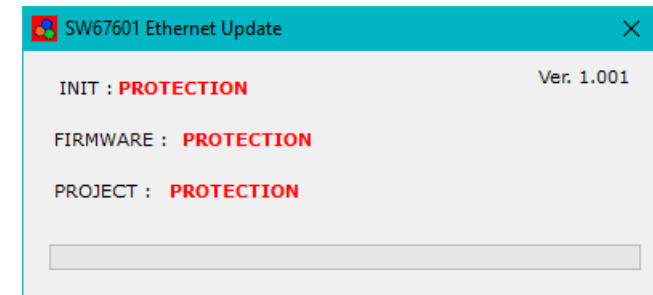

Figure 6: "Protection" window



In the case of HD67601 you have to use the software "SW67601": [www.adfweb.com/download/filefold/SW67601.zip](http://www.adfweb.com/download/filefold/SW67601.zip).

**SERIAL PROTOCOL:**



To send/receive PROFINET data from a master device, it is necessary to follow these instructions:

Master PROFINET → HD67601-xxx-A1

Byte 0	Byte 1	Byte 2	Byte 3	Byte 4	Byte 5	Byte 6
YY	ZZ	Data...	...	...	...	...data

In the byte ZZ and the less significant bit of YY the length of data that follow must be written; the most significant bit of YY must be toggled every time a new message must be sent on serial.

Byte 0 (YY)								Byte 1 (ZZ)							
Bit 7	Bit 6	Bit 5	Bit 4	Bit 3	Bit 2	Bit 1	Bit 0	Bit 7	Bit 6	Bit 5	Bit 4	Bit 3	Bit 2	Bit 1	Bit 0
	0	0	0	0	0	0									

-  Toggle between 0 and 1
-  0...498 (number of bytes to send on serial)
- 0 "0" must be written

Examples:

- Send on serial 4 bytes: 00 04 01 02 03 04
- Send again the same 4 bytes: 80 04 01 02 03 04
- Send 8 bytes: 00 08 05 06 07 08 09 0A 0B 0C



HD67601-xxx-A1 → master PROFINET

Byte 0	Byte 1	Byte 2	Byte 3	Byte 4	Byte 7	Byte 6
YY	ZZ	Data...	...	...	...	...data

In the byte ZZ and the less significant bit of YY the length of data that follow is written; the other bits are used for send a progressive number .

Byte 0 (YY)								Byte 1 (ZZ)							
Bit 7	Bit 6	Bit 5	Bit 4	Bit 3	Bit 2	Bit 1	Bit 0	Bit 7	Bit 6	Bit 5	Bit 4	Bit 3	Bit 2	Bit 1	Bit 0

- 0...127 (counter incremented after every frame received)
- 0...498 (number of bytes received from serial)

Examples:

- Received on serial 4 bytes: 02 04 01 02 03 04
- Received the same 4 bytes again: 04 04 01 02 03 04
- Received 8 bytes: 06 08 05 06 07 08 09 0A 0B 0C



Note:

The time for considering the receiving frame finished is when there is a idle time between bytes of 2tbit.



Note:

If the Converter receives more than 498 bytes in a single frame, the remaining bytes are deleted and only the firsts 498 are sent to the master PROFINET.



### ORDERING INFORMATIONS:

The ordering part number is formed by a valid combination of the following:

**HD67601 - xxx - x x**

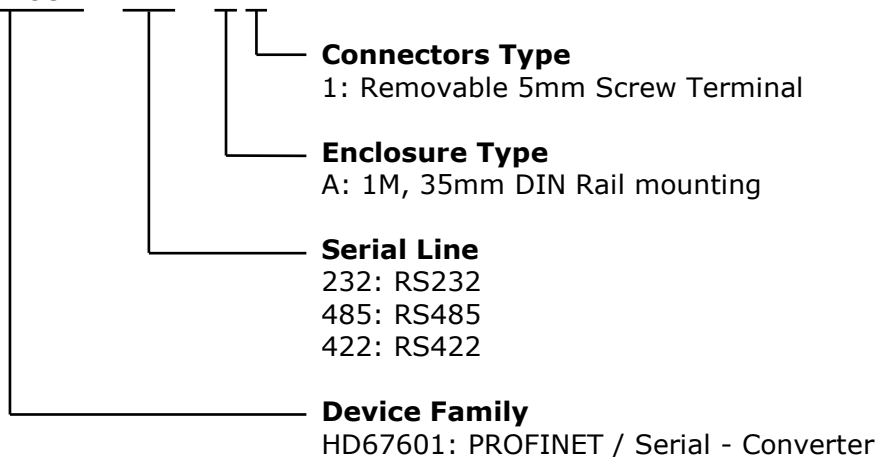

Order Code: **HD67601-232-A1** - PROFINET / Serial - Converter (RS232 serial)

Order Code: **HD67601-485-A1** - PROFINET / Serial - Converter (RS485 serial)

Order Code: **HD67601-422-A1** - PROFINET / Serial - Converter (RS422 serial)

### ACCESSORIES:

Order Code: **AC34001** - 35mm Rail DIN - Power Supply 220/240V AC 50/60Hz – 12 V AC

Order Code: **AC34002** - 35mm Rail DIN - Power Supply 110V AC 50/60Hz – 12 V AC

### PLC CONFIGURATION:

The configuration and commissioning of the PROFINET Converter as described on the following pages was accomplished with the help of the TIA Portal software by Siemens. In the case of using a control system from another supplier, refer to attend to the associated documentation.

These are the steps to follow:

- 1) Install the description file of the module.

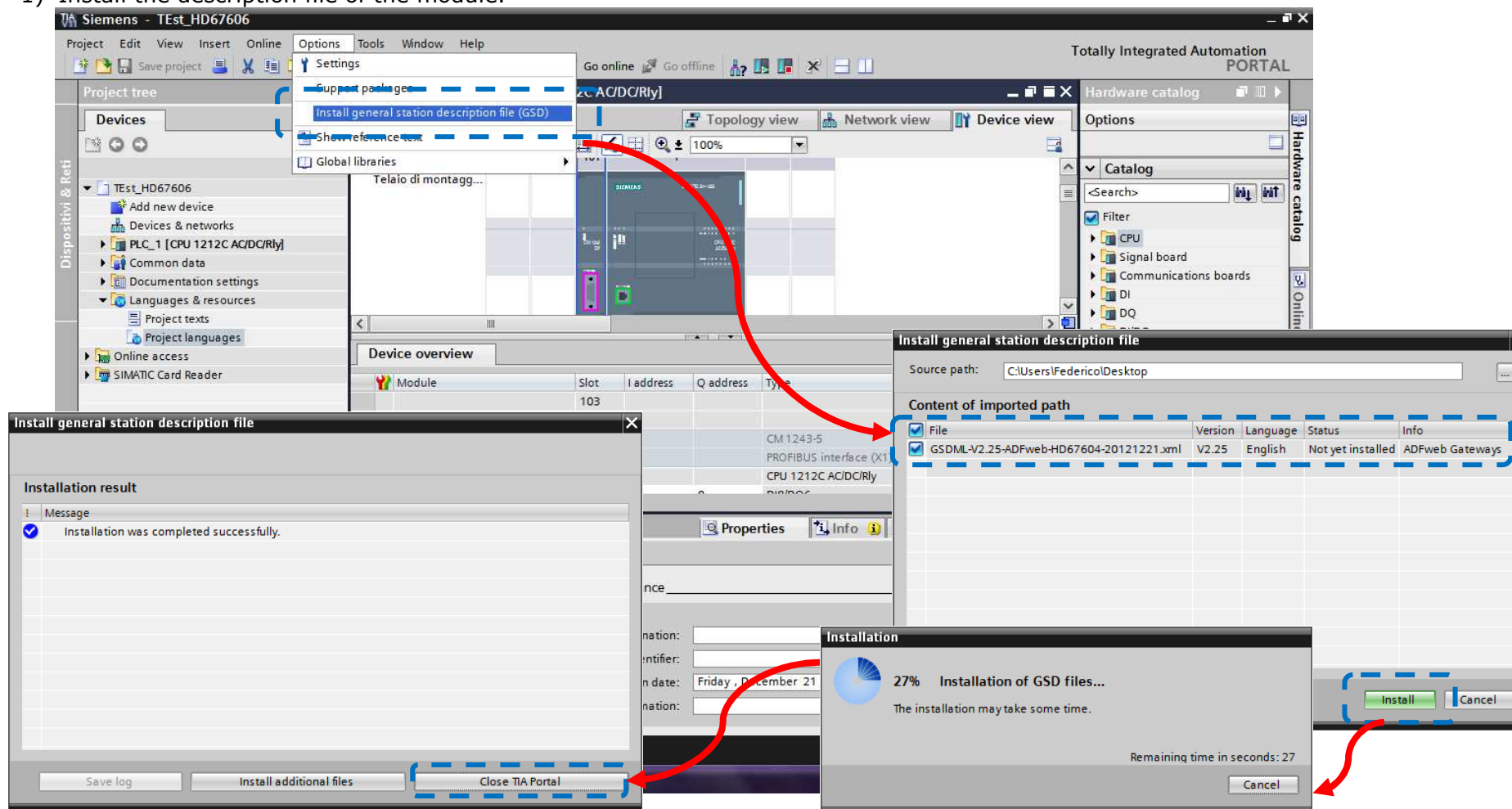

2) Import the module in the network; connect the device to the PLC network and edit the parameters of IP, station name etc.

The screenshot shows the Siemens SIMATIC Manager software interface. The main window displays a network diagram with a PLC\_1 (CPU 1212C) connected to a SERIAL CAN device (PLC\_1) and a DP-NORM device. Below the diagram is a 'Network overview' table and a 'Properties' dialog for the IE1 interface.

Device	Type	Address in subnet	Subnet	Master system	Comment
SIMATIC 1200 station_1	SIMATIC 1200 station				
PLC_1	CPU 1212C AC/DC/Rly				
GSD device_1	GSD device				
SERIAL	CAN				

The 'Properties' dialog for the IE1 interface shows the following configuration:

- Use IP protocol
- Set IP address in the project
  - IP address: 192 . 168 . 2 . 139
  - Subnet mask: 255 . 255 . 255 . 0
  - Use IP router
  - Router address: 0 . 0 . 0 . 0
- Set IP address using a different method

3) Load the configuration into the PLC.

**Extended download to device**

Configured access nodes of "PLC\_1"

Device	Device type	Type	Address	Subnet
PLC_1	CPU 1212C AC/D...	PN/IE	192.168.2.50	PN/IE_1
CM 1243-5	CM 1243-5	PROFIBUS	2	

Type of the PG/PC interface:

PG/PC interface:

Connection to subnet:

1st gateway:

Accessible devices in target subnet:  Show all accessible devices

Device	Device type	Type	Address	Target device
PLC_1	CPU 1212C AC/D...	PN/IE	192.168.2.50	PLC_1
--	--	PN/IE	Access address	--

Flash LED

Refresh

Online status information:  
 Connected to address 192.168.2.50  
 Scanning ended.

Load Cancel

**Load preview**

**?** Check before loading

Status	!	Target	Message	Action
+	✓	PLC_1	Ready for loading.	
	✓	▶ Stop modules	All modules will be stopped for downloading to device.	Stop all
	✓	▶ Device configurati...	Delete and replace system data in target	Download to device
	✓	▶ Software	Download software to device	Consistent download
	✓	▶ Additional inform...	There are differences between the settings for the project and the se	<input checked="" type="checkbox"/> Overwrite all

Refresh

Finish Load Cancel

**DISCLAIMER:**

All technical content within this document can be modified without notice. The content of the document is a under continual renewal. For losses due to fire, earthquake, third party access or other accidents, or intentional or accidental abuse, misuse, or use under abnormal conditions repairs are charged to the user. ADFweb.com S.r.l. will not be liable for accidental loss of use or inability to use this product, such as loss of business income. ADFweb.com S.r.l. shall not be liable for consequences of improper use.

**OTHER REGULATIONS AND STANDARDS:****WEEE INFORMATION**

Disposal of old electrical and electronic equipment (as in the European Union and other European countries with separate collection systems).

— This symbol on the product or on its packaging indicates that this product may not be treated as household rubbish. Instead, it should be taken to an applicable collection point for the recycling of electrical and electronic equipment. If the product is disposed correctly, you will help prevent potential negative environmental factors and impact of human health, which could otherwise be caused by inappropriate disposal. The recycling of materials will help to conserve natural resources. For more information about recycling this product, please contact your local city office, your household waste disposal service or the shop where you purchased the product.

**RESTRICTION OF HAZARDOUS SUBSTANCES DIRECTIVE**

The device respects the 2002/95/EC Directive on the restriction of the use of certain hazardous substances in electrical and electronic equipment (commonly referred to as Restriction of Hazardous Substances Directive or RoHS).

**CE MARKING**

The product conforms with the essential requirements of the applicable EC directives.



**WARRANTIES AND TECHNICAL SUPPORT:**

For fast and easy technical support for your ADFweb.com SRL products, consult our internet support at [www.adfweb.com](http://www.adfweb.com). Otherwise contact us at the address [support@adfweb.com](mailto:support@adfweb.com)

**RETURN POLICY:**

If while using your product you have any problem and you wish to exchange or repair it, please do the following:

- Obtain a Product Return Number (PRN) from our internet support at [www.adfweb.com](http://www.adfweb.com). Together with the request, you need to provide detailed information about the problem.
- Send the product to the address provided with the PRN, having prepaid the shipping costs (shipment costs billed to us will not be accepted).

If the product is within the warranty of twelve months, it will be repaired or exchanged and returned within three weeks. If the product is no longer under warranty, you will receive a repair estimate.

