

User Manual

Revision 1.000
English

Modbus TCP / Modbus ASCII - Converter

(Order Code: HD67522-232-A1, HD67522-232-B2,
HD67522-485-A1, HD67522-485-B2,
HD67522-422-A1)

Benefits and Main Features:

- Very easy to configure
- 32mm Rail DIN mount
- ⊕ Wide supply input range
- ⊕
- ⊕

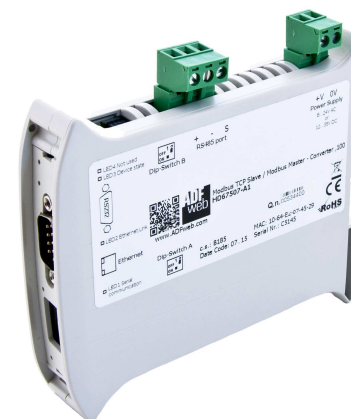

User Manual



INDEX:

	Page
INDEX	2
UPDATED DOCUMENTATION	2
REVISION LIST	2
WARNING	2
TRADEMARKS	2
SECURITY ALERT	3
EXAMPLE OF CONNECTION	4
CONNECTION SCHEME	6
CHARACTERISTICS	11
CONFIGURATION	11
POWER SUPPLY	12
FUNCTION MODES	13
LEDS	14
RS485	15
RS422	16
RS232	17
ETHERNET	17
USE OF COMPOSITOR SW67522	18
NEW PROJECT / OPEN PROJECT	19
SOFTWARE OPTIONS	20
SET COMMUNICATION	21
OPERATION MODE (for "Modbus TCP Slave ↔ Modbus ASCII Master")	27
OPERATION MODE (for "Modbus ASCII Slave ↔ Modbus TCP Master")	30
UPDATE DEVICE	36
MECHANICAL DIMENSIONS	38
ORDER CODES	40
ACCESSORIES	41
DISCLAIMER	42
OTHER REGULATIONS AND STANDARDS	42
WARRANTIES AND TECHNICAL SUPPORT	43
RETURN POLICY	43

UPDATED DOCUMENTATION:

Dear customer, we thank you for your attention and we remind you that you need to check that the following document is:

- Updated
- Related to the product you own

To obtain the most recently updated document, note the "document code" that appears at the top right-hand corner of each page of this document.

With this "Document Code" go to web page www.adfweb.com/download/ and search for the corresponding code on the page. Click on the proper "Document Code" and download the updates.

REVISION LIST:

Revision	Date	Author	Chapter	Description
1.000	09/05/2016	Ff	All	First release version

WARNING:

ADFweb.com reserves the right to change information in this manual about our product without warning. ADFweb.com is not responsible for any error this manual may contain.

TRADEMARKS:

All trademarks mentioned in this document belong to their respective owners.

SECURITY ALERT:**GENERAL INFORMATION**

To ensure safe operation, the device must be operated according to the instructions in the manual. When using the device are required for each individual application, legal and safety regulation. The same applies also when using accessories.

INTENDED USE

Machines and systems must be designed so the faulty conditions do not lead to a dangerous situation for the operator (i.e. independent limit switches, mechanical interlocks, etc.).

QUALIFIED PERSONNEL

The device can be used only by qualified personnel, strictly in accordance with the specifications.

Qualified personnel are persons who are familiar with the installation, assembly, commissioning and operation of this equipment and who have appropriate qualifications for their job.

RESIDUAL RISKS

The device is state of the art and is safe. The instrument can represent a potential hazard if they are inappropriately installed and operated by personnel untrained. These instructions refer to residual risks with the following symbol:

 This symbol indicates that non-observance of the safety instructions is danger for people to serious injury or death and / or the possibility of damage.

CE CONFORMITY

The declaration is made by us. You can send an email to or give us a call if you need it.

EXAMPLE OF CONNECTION:

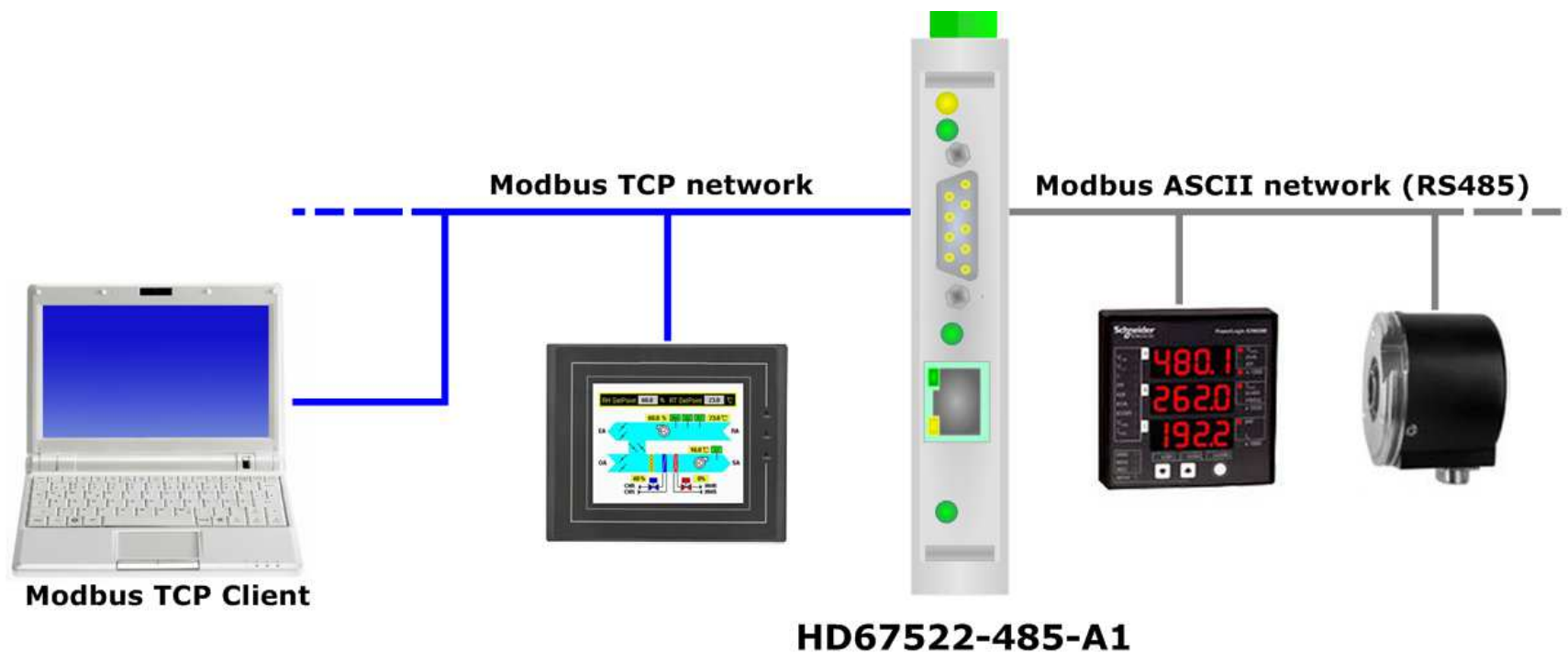

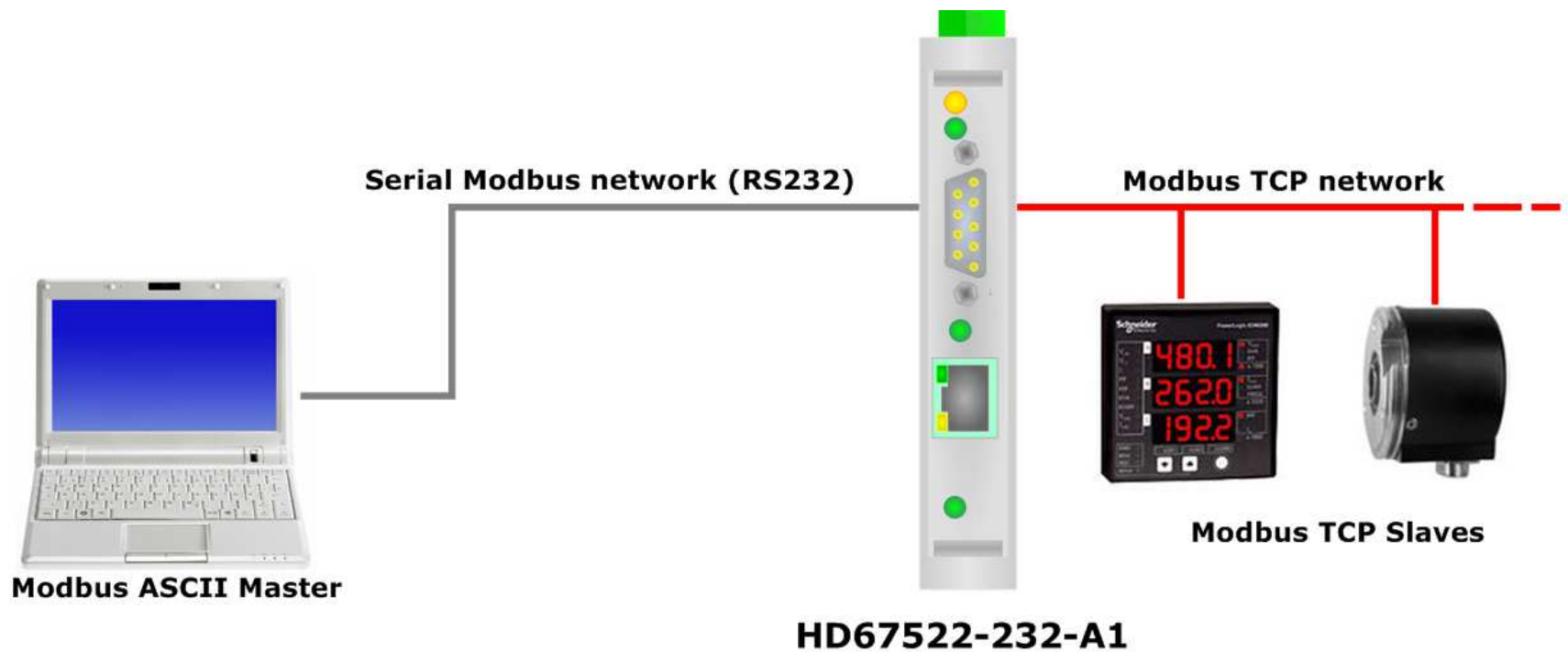

CONNECTION SCHEME:

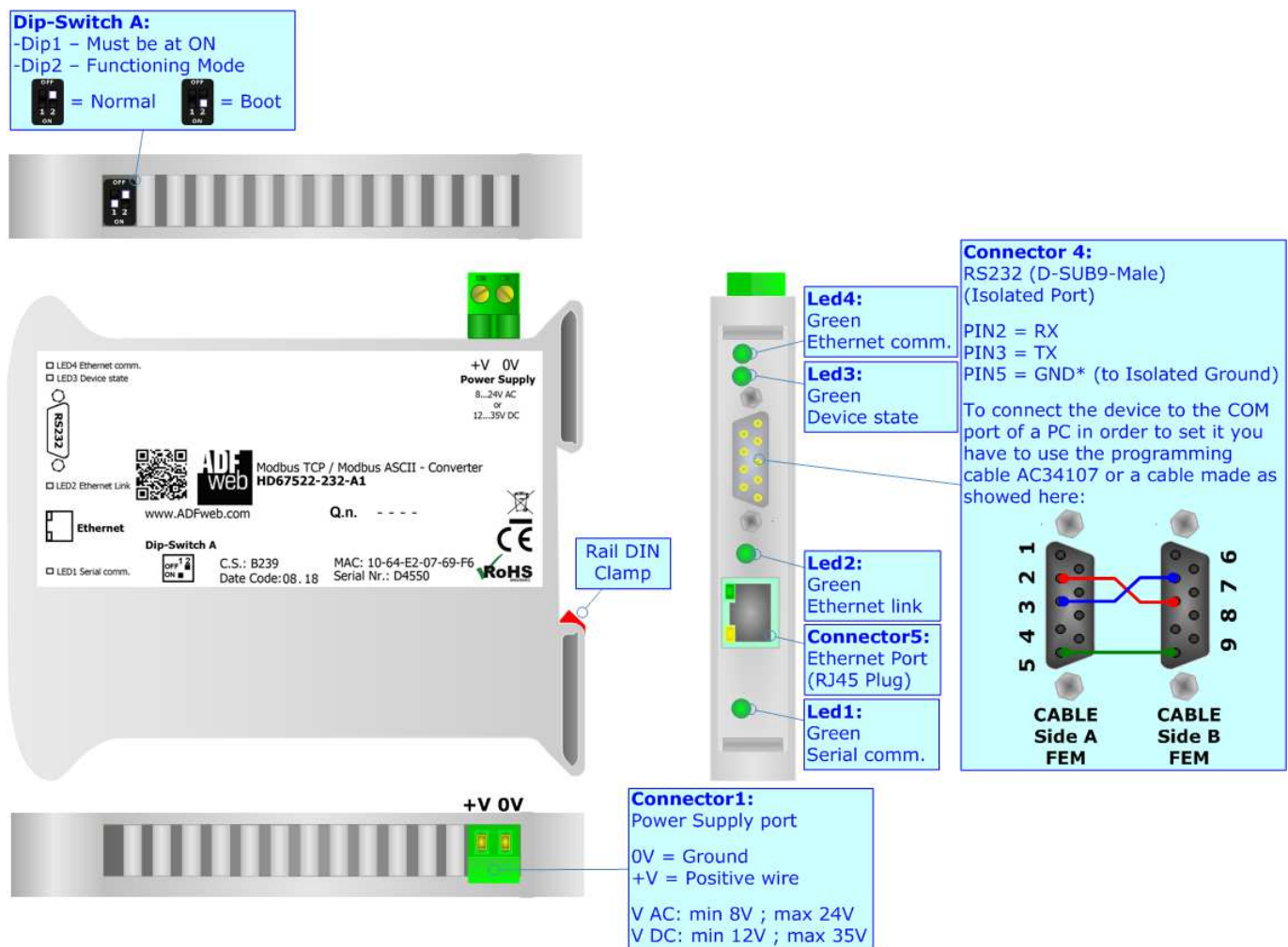

Figure 1a: Connection scheme for HD67522-232-A1

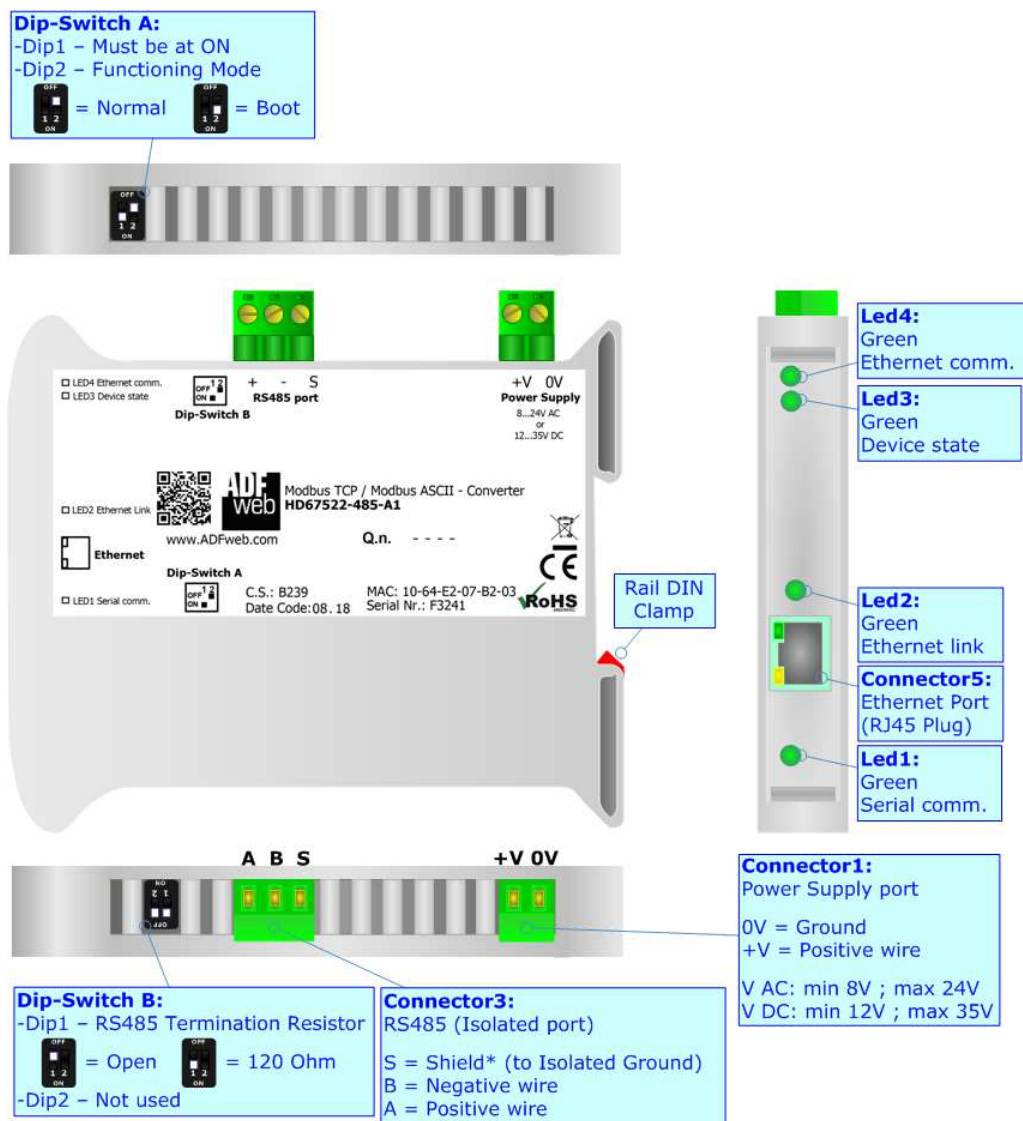

Figure 1b: Connection scheme for HD67522-485-A1

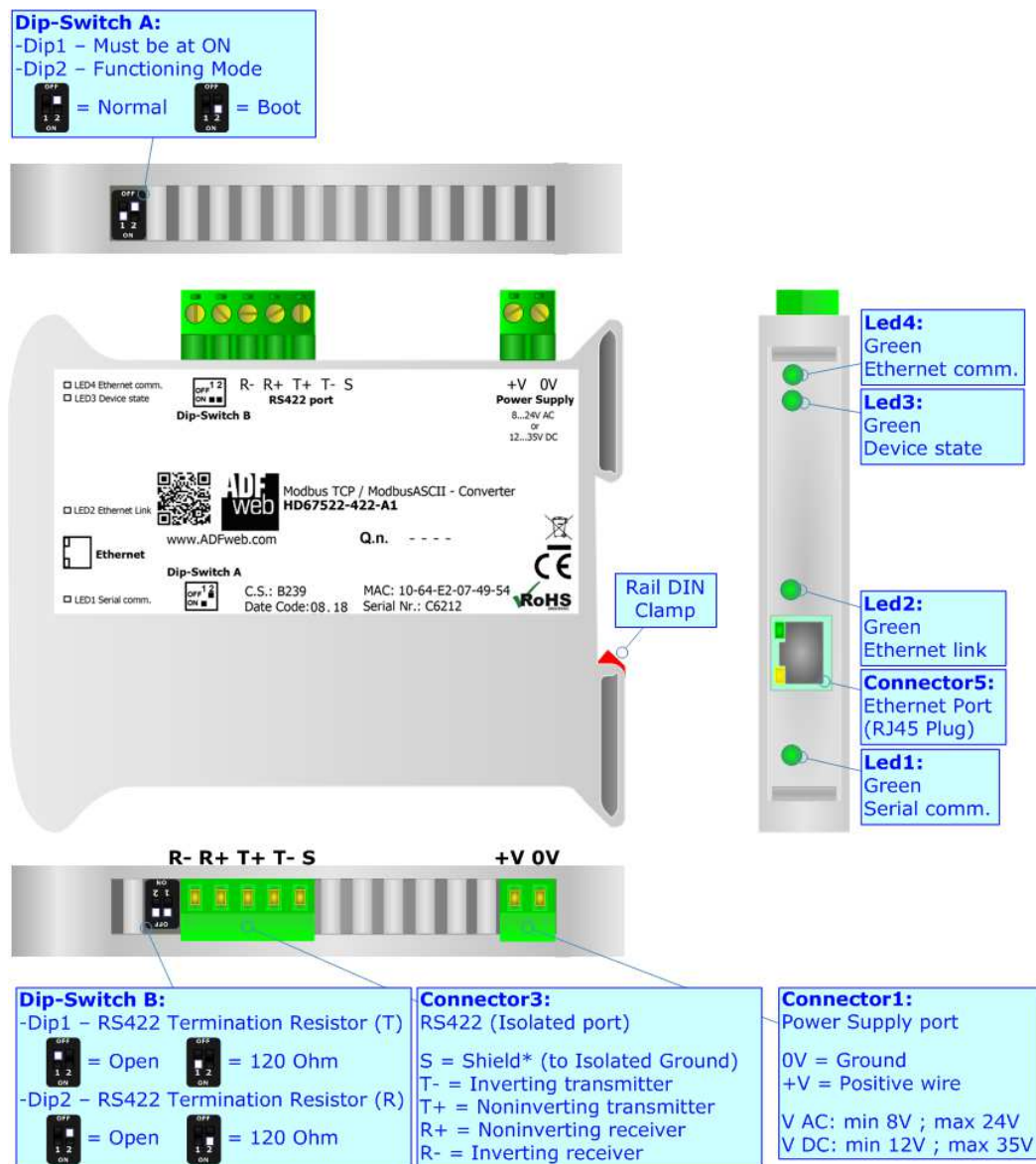

Figure 1c: Connection scheme for HD67522-422-A1

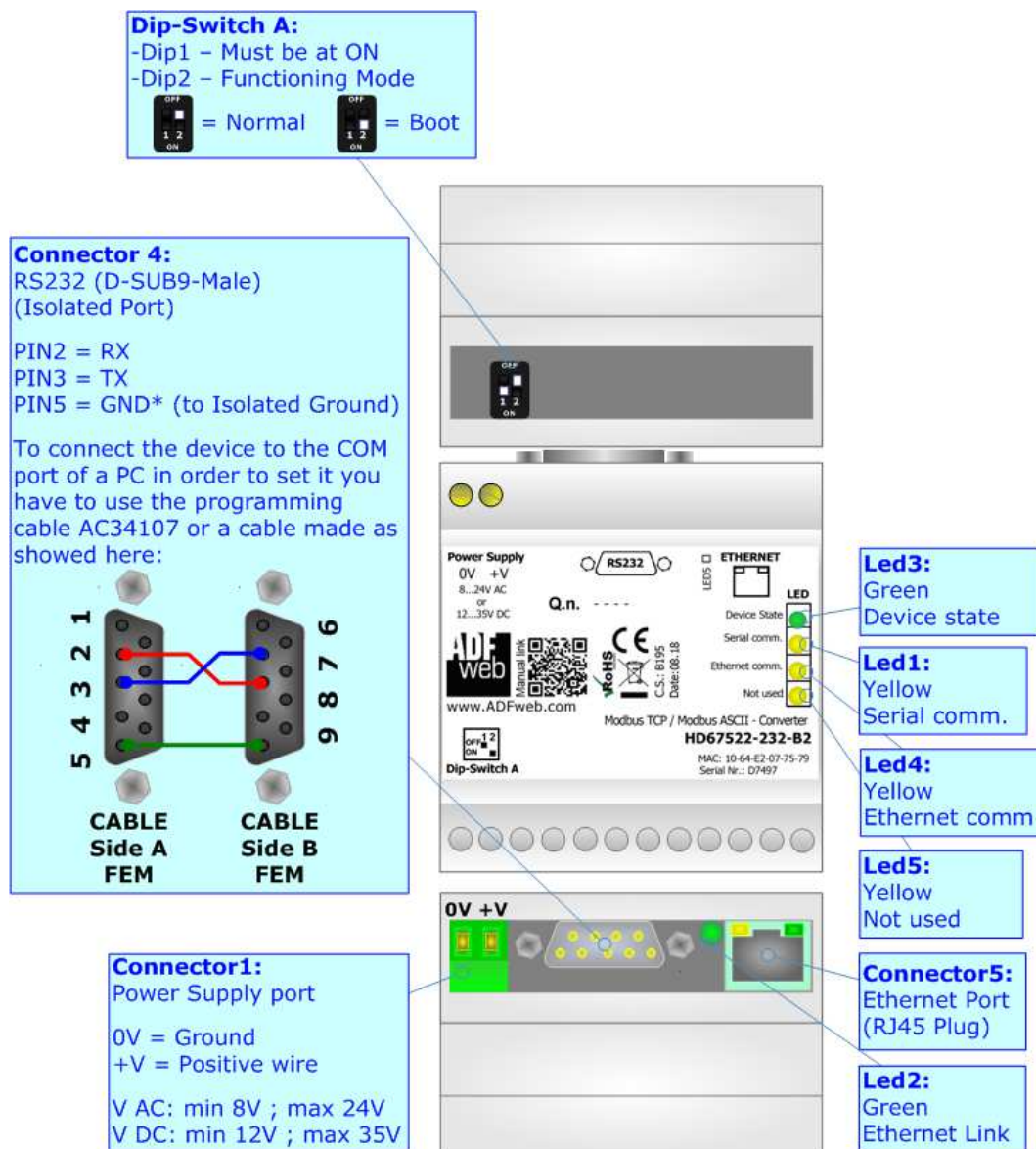

Figure 1d: Connection scheme for HD67522-232-B2

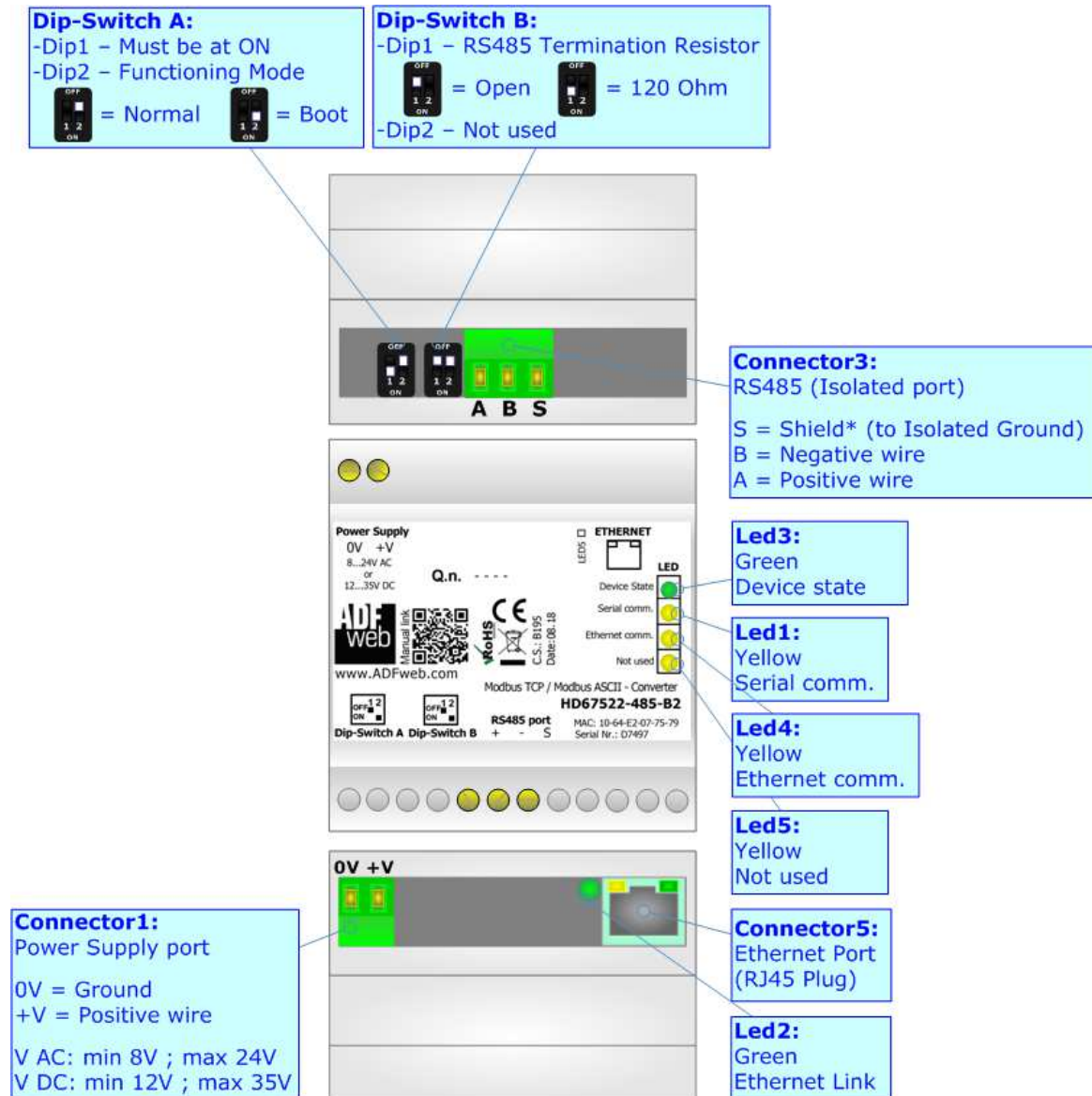

Figure 1e: Connection scheme for HD67522-485-B2

CHARACTERISTICS:

The “Modbus TCP / Modbus ASCII- Converter” allows the following characteristics:

- two-directional information between networks Modbus ASCII and Modbus TCP;
- electrical isolation between Modbus ASCII – Modbus TCP, Power Supply – Modbus TCP, Power Supply – Modbus ASCII;
- Mountable on Rail DIN;
- Wide power supply input range: 8...24V AC or 12...35V DC;
- Wide temperature range: -40°C / 85°C [-40°F / +185°F].

CONFIGURATION:

You need Compositor SW67522 software on your PC in order to perform the following:

- Define the parameter of Modbus ASCII;
- Define the parameter of Modbus TCP;
- Update the device.

POWER SUPPLY:

The devices can be powered at 8...24V AC and 12...35V DC. The consumption depends to the code of the device. For more details see the two tables below.

VAC		VDC	
Vmin	Vmax	Vmin	Vmax
8V	24V	12V	35V

Consumption at 24V DC:

Device	Consumption [W/VA]
HD67522-xxx-A1	3.5
HD67522-xxx-B2	3.5



Caution: Not reverse the polarity power

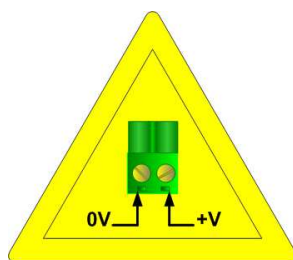

HD67522-xxx-A1
HD67522-xxx-B2

Connector1:
Power Supply port
0V = Ground
+V = Positive wire
V AC: min 8V ; max 24V
V DC: min 12V ; max 35V

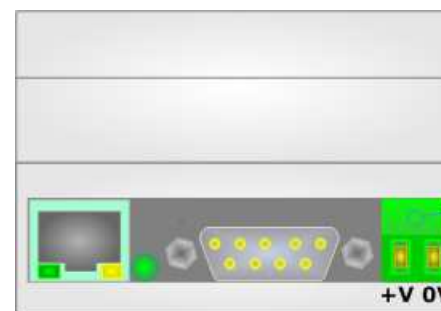
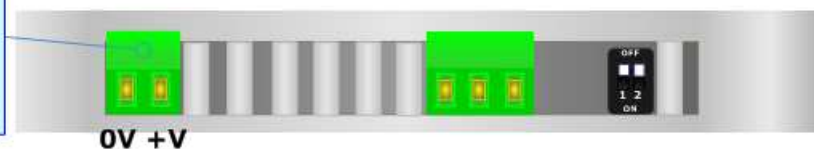

Connector1:
Power Supply port
0V = Ground
+V = Positive wire
V AC: min 8V ; max 24V
V DC: min 12V ; max 35V

FUNCTION MODES:

The device has got two function modes depending on the position of the 'Dip2 of Dip-Switch A':

- The first, with 'Dip2 of Dip-Switch A' at "OFF" position, is used for the normal working of the device.
- The second, with 'Dip2 of Dip-Switch A' at "ON" position, is used for uploading the Project and/or Firmware.

For the operations to follow for the updating, see 'UPDATE DEVICE' section.

According to the functioning mode, the LEDs will have specific functions, see 'LEDS' section.

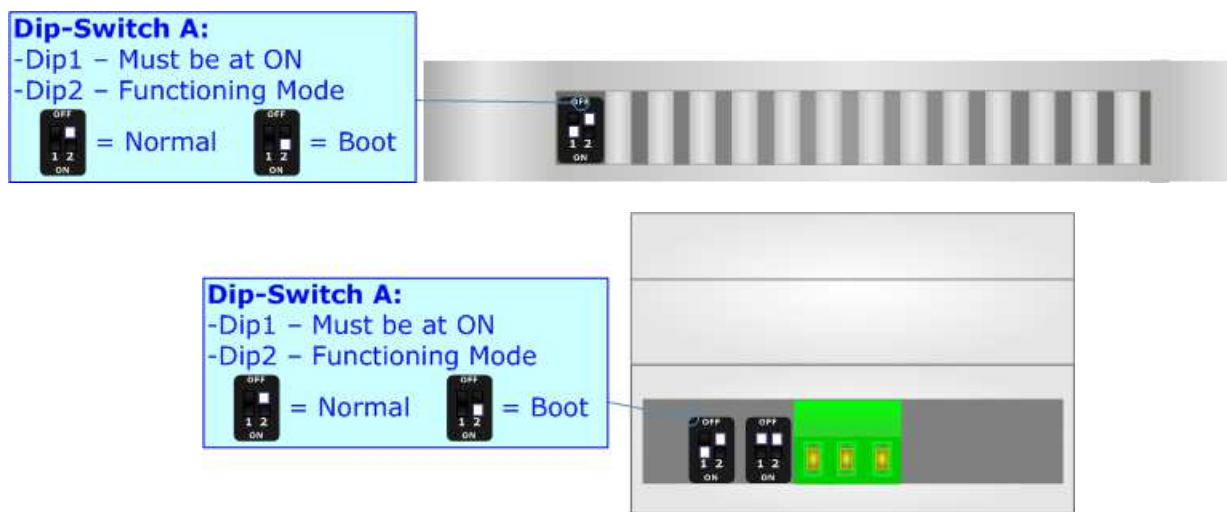
**Warning:**

Dip1 of 'Dip-Switch A' must be at ON position to work even if the Ethernet cable is not inserted.

LEDS:

The device has got four LEDs that are used to give information of the functioning status. The various meanings of the LEDs are described in the table below.

LED	Normal Mode	Boot Mode
1: Serial communication	Blinks when Modbus ASCII frames are received	Blinks quickly: Boot state Blinks very slowly (~0.5Hz): update in progress
2: Ethernet Link	ON: Ethernet cable connected OFF: Ethernet cable disconnected	ON: Ethernet cable connected OFF: Ethernet cable disconnected
3: Device state	Blinks slowly (~1Hz)	Blinks quickly: Boot state Blinks very slowly (~0.5Hz): update in progress
4: Ethernet communication	Blinks when Modbus TCP frames are received	Blinks quickly: Boot state Blinks very slowly (~0.5Hz): update in progress

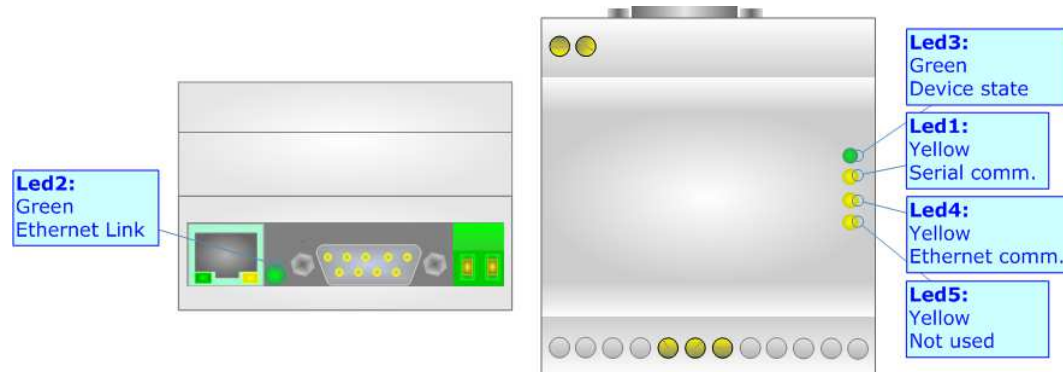
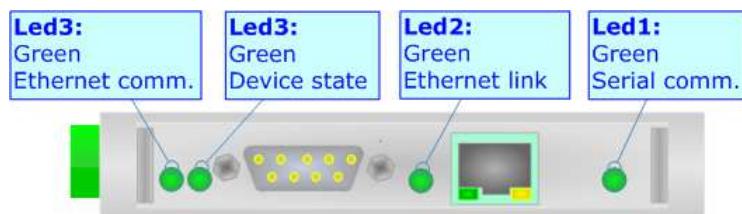

RS485:

For terminate the RS485 line with a 120Ω resistor it is necessary to put ON dip 1, like in figure.

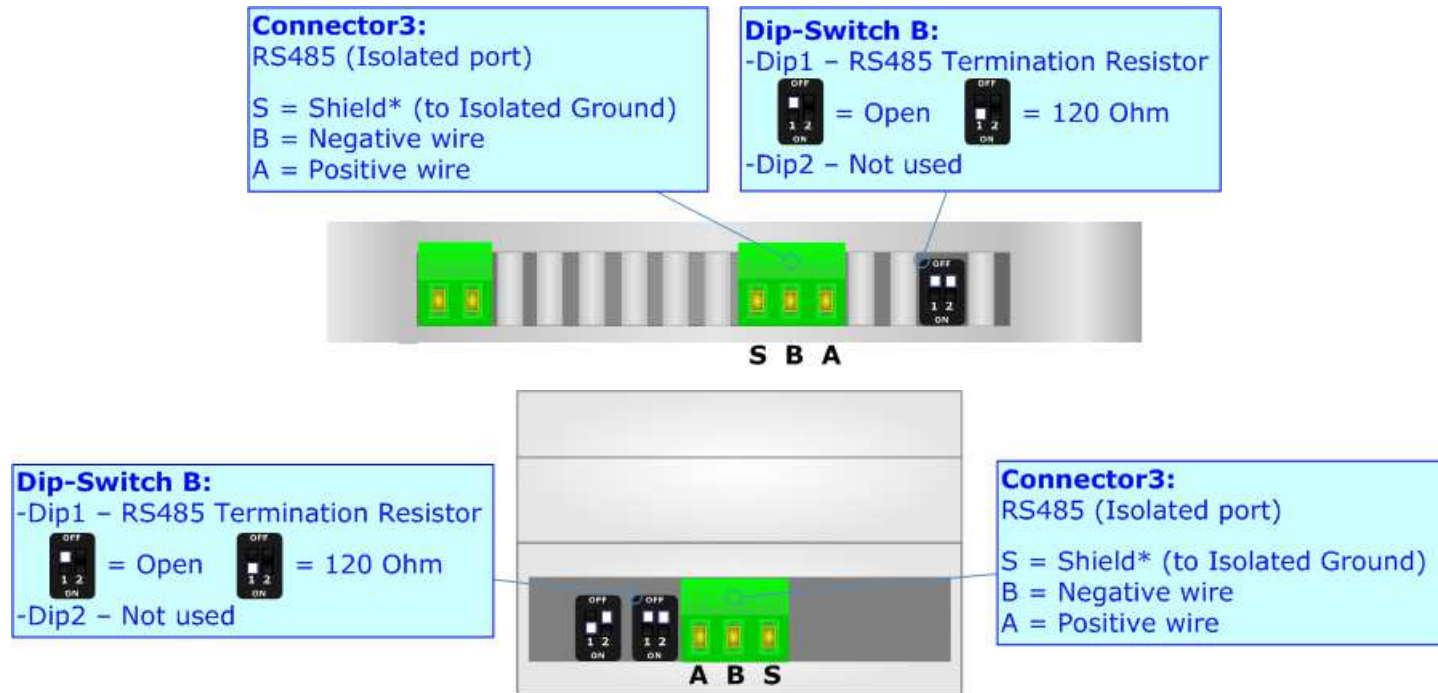

The maximum length of the cable should be 1200m (4000 feet).

Here some codes of cables:

- Belden: p/n 8132 - 2x 28AWG stranded twisted pairs conductor + foil shield + braid shield;
- Belden p/n 82842 - 2x 24AWG stranded twisted pairs conductor + foil shield + braid shield;
- Tasker: p/n C521 - 1x 24AWG twisted pair conductor + foil shield + braid shield;
- Tasker: p/n C522 - 2x 24AWG twisted pairs conductor + foil shield + braid shield.

RS422:

For terminate the RS422 line with a 120Ω resistor it is necessary to put ON dip 1 for T line and/or put ON dip 2 for R line, like in figure.

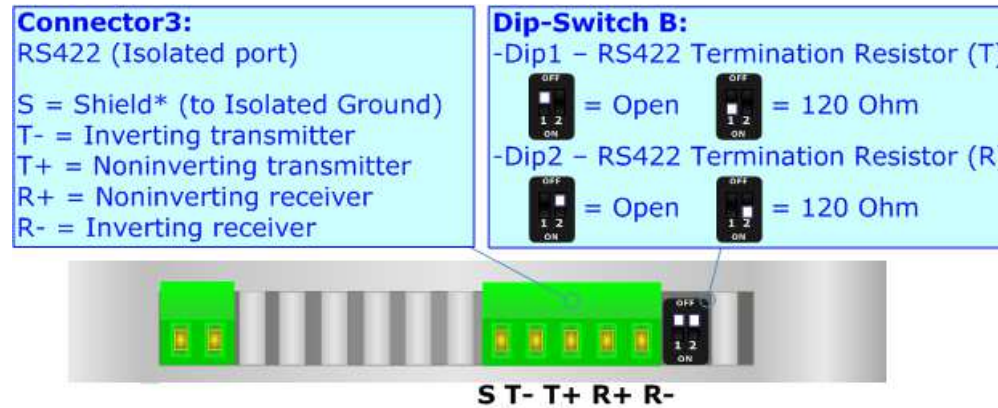

The maximum length of the cable should be 1200m (4000 feet).

RS232:

The connection from RS232 socket to a serial port (example one from a personal computer) must be made with a Null Modem cable (a serial cable where the pins 2 and 3 are crossed).

It is recommended that the RS232 cable not exceed 15 meters.

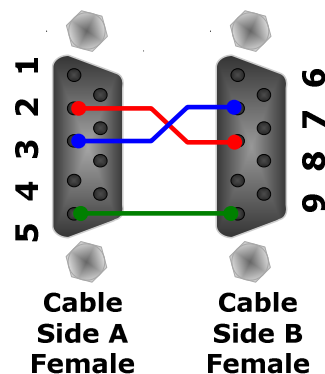

ETHERNET:

The Ethernet connection must be made using Connector5 of HD67522 with at least a Category 5E cable. The maximum length of the cable should not exceed 100m. The cable has to conform to the T568 norms relative to connections in cat.5 up to 100 Mbps. To connect the device to a Hub/Switch the use of a straight cable is recommended. To connect the device to a PC/PLC/other the use of a cross cable is recommended.

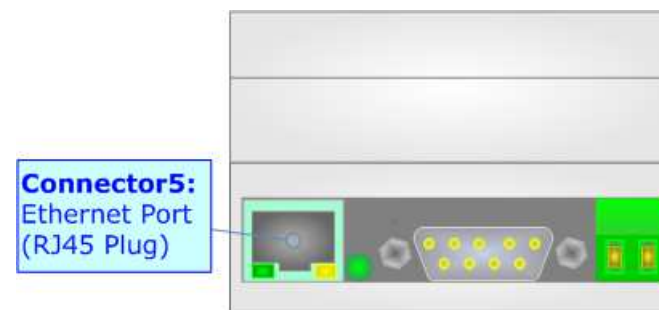

USE OF COMPOSITOR SW67522:

To configure the Converter, use the available software that runs with Windows called SW67522. It is downloadable on the site www.adfweb.com and its operation is described in this document. *(This manual is referenced to the last version of the software present on our web site)*. The software works with MSWindows (XP, Vista, Seven, 8, 10; 32/64bit).

When launching the SW67522, the window below appears (Fig. 2).

 **Note:**
It is necessary to have installed .Net Framework 4.



Figure 2: Main window for SW67522

NEW CONFIGURATION / OPEN CONFIGURATION:

The “**New Configuration**” button creates the folder which contains the entire device’s configuration.

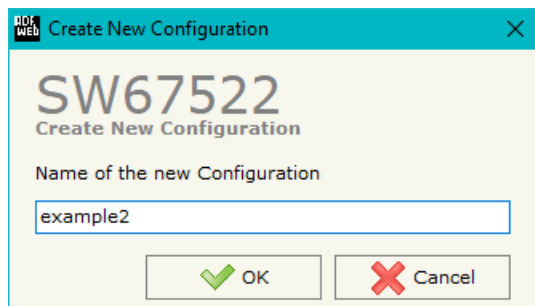

A device’s configuration can also be imported or exported:

- To clone the configurations of a programmable “Modbus TCP / Modbus ASCII - Converter” in order to configure another device in the same manner, it is necessary to maintain the folder and all its contents;
- To clone a project in order to obtain a different version of the project, it is sufficient to duplicate the project folder with another name and open the new folder with the button “**Open Configuration**”.

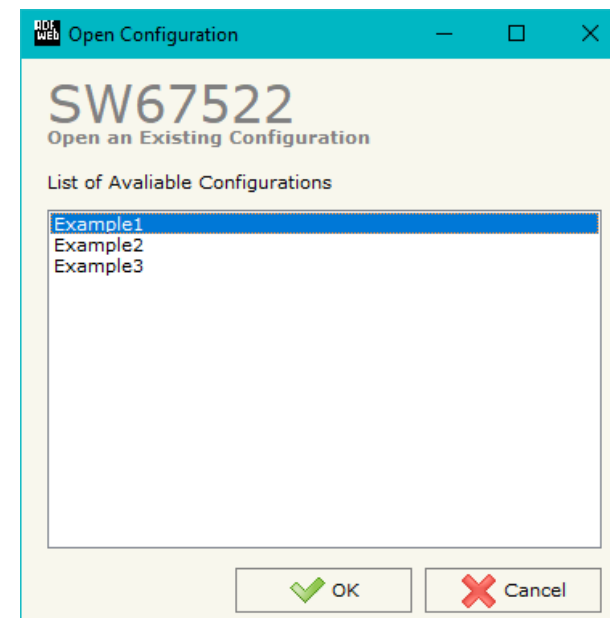

SOFTWARE OPTIONS:

By pressing the “**Settings**” () button there is the possibility to change the language of the software and check the updatings for the compositor.

In the section “Language” it is possible to change the language of the software.

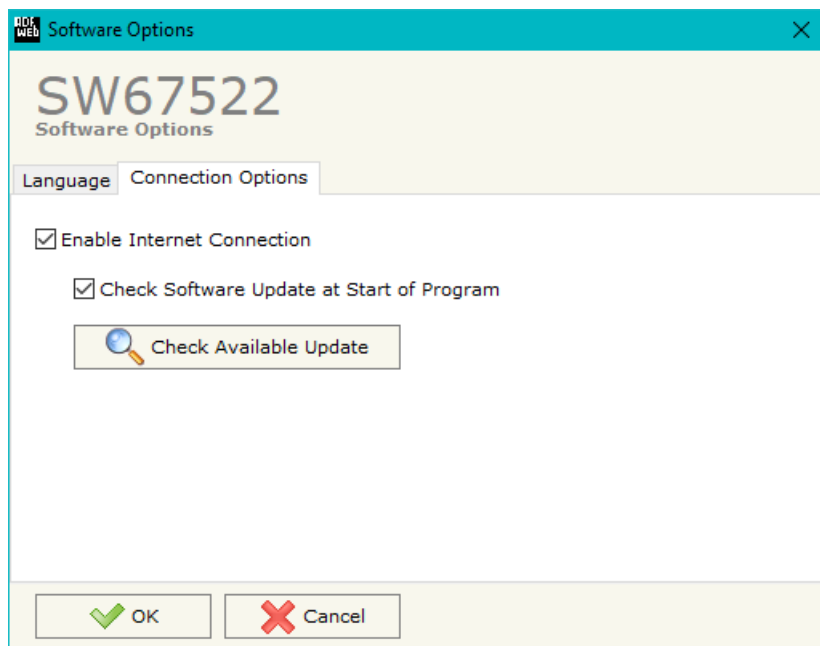

In the section “Connection Options”, it is possible to check if there are some updatings of the software compositor in ADFweb.com website. Checking the option “**Check Software Update at Start of Program**”, the SW67522 check automatically if there are updatings when it is launched.

SET COMMUNICATION:

This section defines the fundamental communication parameters of two Buses, Modbus ASCII and Modbus TCP.

By pressing the “**Set Communication**” button from the main window for SW67522 (Fig. 2) the window “Set communication” appears (Fig. 3).

The window is divided in different sections in order to define the different parameters of the converter:

- Working Mode
- Operation Mode
- Modbus (Master/Slave)
- Modbus TCP (Master/Slave)

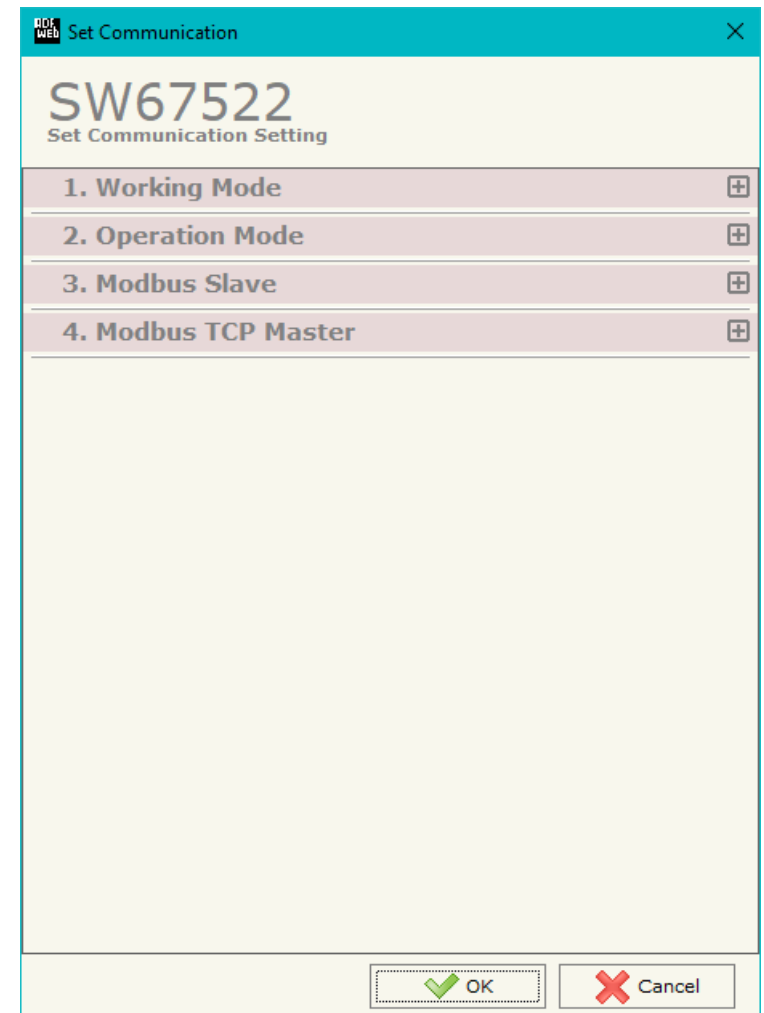

Figure 3a: "Set Communication" window

WORKING MODE:

This section is used to define the working mode of the converter. It is possible to define:

- **Modbus TCP Slave ↔ Modbus ASCII Master:** it is used to interface a Modbus TCP Master with one or more Modbus ASCII slaves.
- **Modbus ASCII Slave ↔ Modbus TCP Master:** it is used to interface a Modbus ASCII Master with one or more Modbus TCP slaves.

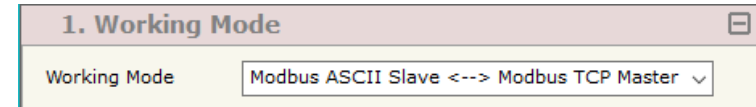

Figure 3b: "Set Communication → Working Mode" window

**Note:**

When you change the Working Mode, it is necessary to update the firmware of the converter too.

If “Modbus TCP Slave ↔ Modbus ASCII Master” is set in the section “Set Communication”, the window appears like below.

OPERATION MODE:

The section “Operation Mode” defines the operation of the Converter in “**Routing Mode**” or “**NAT Mode**” (see the description at page 27).

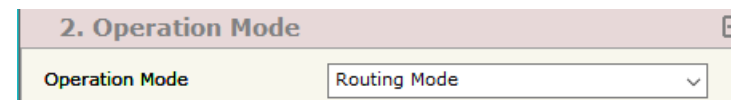

Figure 3c: “Set Communication → Operation Mode” window

MODBUS TCP SLAVE:

This section is used to define the general parameters of Modbus TCP side. The means of the fields are:

- In the field “**IP ADDRESS**” the IP address of the converter is defined;
- In the field “**SUBNET Mask**” the Subnet Mask of the converter is defined;
- In the field “**GATEWAY**” the default gateway of the net is defined. This feature can be enabled or disabled pressing the Check Box field. This feature is used for going out of the net;
- In the field “**Port**” the port used for Modbus TCP communication is defined;
- Checking “**Enable UDP Port**” field it is possible to do a Broadcast request. This request must be made at Port 64223 (\$FADF) with these six byte of data: \$53, \$45, \$41, \$52, \$43, \$48. Each device in response sends a total of 10 Bytes. These bytes are four for the IP and the other for the MAC address (Example of response: 0xC0, 0xA8, 0x01, 0x2A, 0x11, 0x22, 0x33, 0x44, 0x55, 0x58. So the IP is: 192.168.1.42; and the MAC Address: 11-22-33-44-55-58);
- If the field “**Enable Special Command**” is checked, it is possible to send a no-Modbus request through the Converter. i.e. a TCP frame with the first two characters 0x55 and 0xAA is sent in the Modbus ASCII line as is. If you don’t want to send the first two bytes (0x55, 0xAA) in the ASCII line it is possible to check the field “**Cancel the first two bytes**”;
- If the field “**No TCP frame on ASCII Timeout**” is checked, the Converter don’t sends back the reply on TCP (error response) if the Slave ASCII interrogated has not replied.

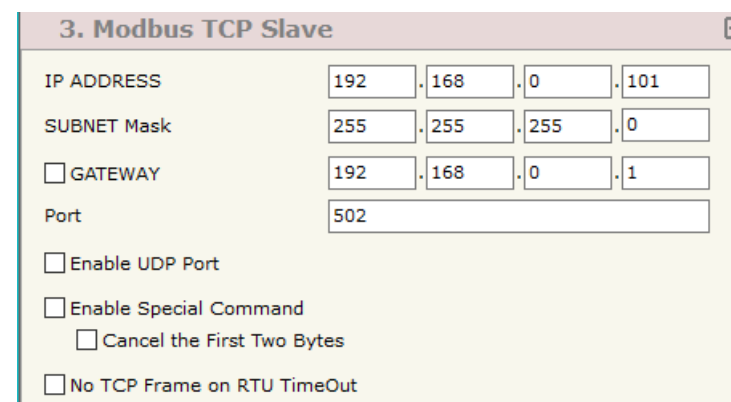
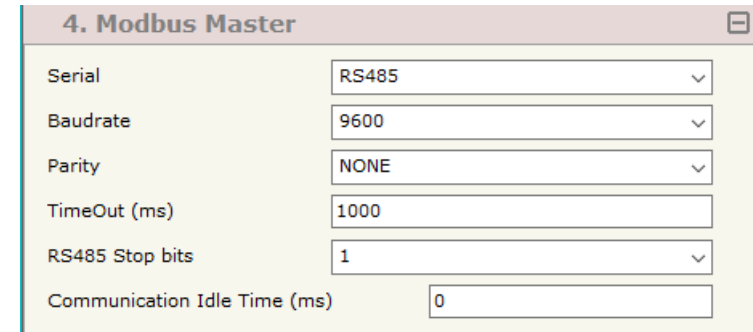

Figure 3d: “Set Communication → Modbus TCP Slave” window

MODBUS MASTER:

This section is used to define the main parameters of Modbus line. The means of the fields are:

- ➔ In the field "**Serial**" the serial port to use is defined;
- ➔ In the field "**Baudrate**" the baudrate for the serial line is defined;
- ➔ In the field "**Parity**" the parity of the serial line is defined;
- ➔ In the field "**TimeOut (ms)**" the maximum time that the converter attends for the answer from the Slave interrogated is defined;
- ➔ In the field "**Stop Bits**" the number of Stop Bits of the serial line is defined;
- ➔ In the field "**Communication Idle Time (ms)**" the delay between the Modbus response from a slave and the following request is defined.



4. Modbus Master	
Serial	RS485
Baudrate	9600
Parity	NONE
TimeOut (ms)	1000
RS485 Stop bits	1
Communication Idle Time (ms)	0

Figure 3e: "Set Communication → Modbus Master" window

If “Modbus ASCII Slave ↔ Modbus TCP Master” is set in the section “Set Communication”, the window appears like below.

OPERATION MODE:

The section “Operation Mode” defines the operation of the Converter in “**Normal Mode (with Translate Table)**”, “**Routing Slave Address**” or “**Work with Fix IP Address**” (see the description at page 30).

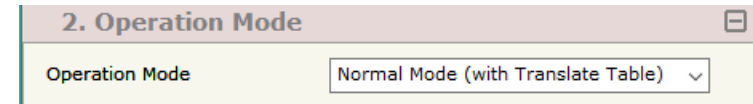

Figure 3f: “Set Communication → Operation Mode” window

MODBUS SLAVE:

This section is used to define the main parameters of Modbus line. The means of the fields are:

- In the field “**Serial**” the serial port to use is defined;
- In the field “**Baudrate**” the baudrate for the serial line is defined;
- In the field “**Parity**” the parity of the serial line is defined;
- In the field “**Stop Bits**” the number of Stop Bits of the serial line is defined;
- In the field “**ID Device**” the address of serial Modbus device is defined. This field can be compiled only if the selected “Operation Mode” is “Normal Mode (with Translate Table)” or “Work with Fix IP Address”;

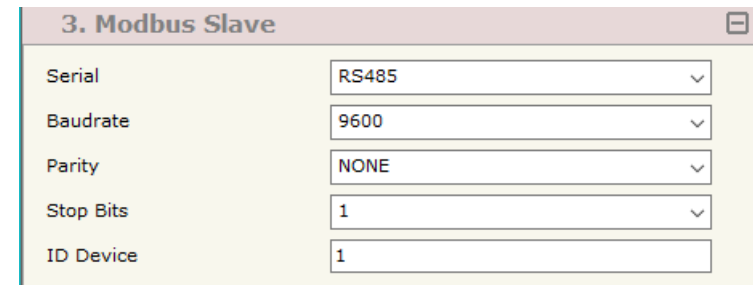
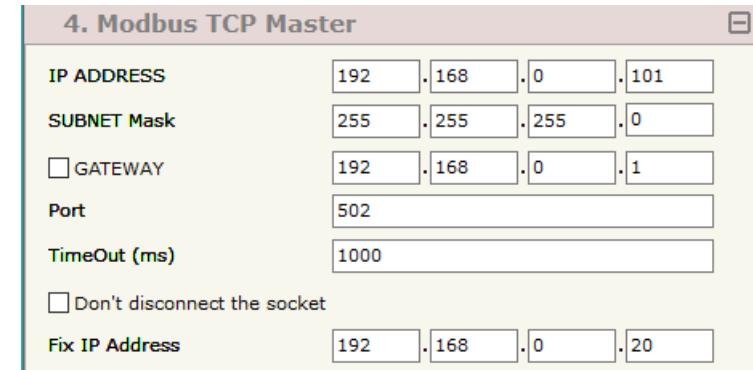

Figure 3g: “Set Communication → Modbus Master” window

MODBUS TCP MASTER:

- In the field "**IP ADDRESS**" the IP address of the converter is defined;
- In the field "**SUBNET Mask**" the Subnet Mask of the converter is defined;
- In the field "**GATEWAY**" the default gateway of the net is defined. This feature can be enabled or disabled pressing the Check Box field. This feature is used for going out of the net;
- In the field "**Port**" the port used for Modbus TCP communication is defined;
- In the field "**Timeout (ms)**" the maximum time that the converter attends for the answer from the Slave interrogated is defined;
- If the field "**Don't disconnect the socket**" is checked, when the Converter receives the TCP response it does not disconnect the opened socket (open the socket only at the first ASCII request and then the socket remains opened); otherwise for every ASCII requests the Converter opens the socket and when it receives the TCP response it closes it;
- In the field "**Fix IP Address**" the IP address of the Modbus TCP slave device to which the converter sends the requests is defined. This field is visible only if the selected "Operation Mode" is "Work with Fix IP Address".



4. Modbus TCP Master				
IP ADDRESS	192	.168	.0	.101
SUBNET Mask	255	.255	.255	.0
<input type="checkbox"/> GATEWAY	192	.168	.0	.1
Port	502			
TimeOut (ms)	1000			
<input type="checkbox"/> Don't disconnect the socket				
Fix IP Address	192	.168	.0	.20

Figure 3h: "Set Communication → Modbus TCP Slave" window

OPERATION MODE (for “Modbus TCP Slave ↔ Modbus ASCII Master”):**ROUTING:**

A few characteristics of the Modbus ASCII package have been modified in the standard of the Modbus TCP protocol. Two bytes of the final CRC were eliminated (no longer necessary for the information to reach its already corrected destination). The first byte of the slave identification was changed, leaving the one that is called PDU. A frame denominated as MBAP header with dimensions of 7 bytes was added to the head of the PDU.

It is composed by the following:

- ➔ Word transaction identifier (recopied from the slave in the response phase);
- ➔ Word protocol identifier (0=Modbus protocol);
- ➔ Word length (number of successive bytes);
- ➔ Byte unit identifier (used for the routing operation).

By using the last byte of the MBAP header, it is possible to carry out the routing from a requested Modbus TCP toward a serial line using the address from the slave which is specified by the byte unit identifier.

Example:

A requested Modbus TCP made in the device as the address 192.168.0.200 for the holding register address \$2000, which is MBAP unit identifier has the value of 2. It will be followed by the request on the serial for the device with the address 2 at the word \$2000.

After the request is made, the ASCII will respond. The master TCP will be given the same response which will be reconstructed according to the specifications of the Modbus TCP.

If the ASCII slave responds with an exception, that exception code will be transmitted again to the TCP master. If the ASCII slave does not respond in the estimated time defined by the Timeout parameter, an exception response will be given: error code \$0B.

NATting:

When NAT operation mode is used, the requested data will be processed through the "Translate Table".

By pressing the "**Translate Table**" button from the main window for SW67522 (Fig. 2), the window "Set Translate Table" appears (Fig. 4).

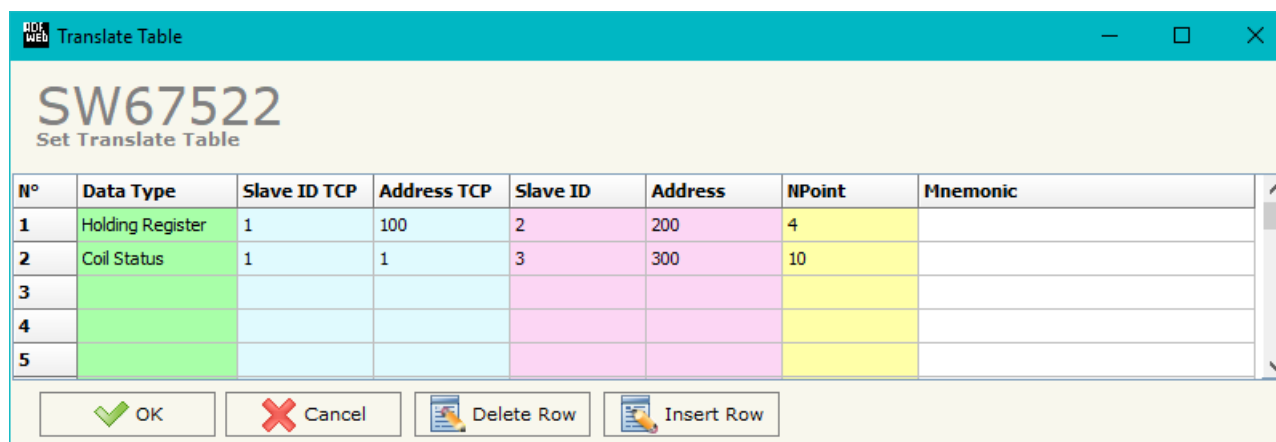

N°	Data Type	Slave ID TCP	Address TCP	Slave ID	Address	NPoint	Mnemonic
1	Holding Register	1	100	2	200	4	
2	Coil Status	1	1	3	300	10	
3							
4							
5							

Figure 4: "Set Translate Table" window

The data of the columns have the following meanings:

- In the field "**Data Type**" the type of data for the Modbus translation is defined;
- In the field "**Slave ID TCP**" the address of the virtual Modbus TCP node is defined;
- In the field "**Address TCP**" the Modbus Address of the virtual TCP node is defined;
- In the field "**Slave ID**" the ID of the Modbus slave to poll is defined;
- In the field "**Address**" the Modbus address of the data on the ASCII device is defined;
- In the field "**NPoint**" the number of consecutive registers to read/write is defined;
- In the field "**Mnemonic**" a brief description is defined.

Example 1:

If you want, from TCP network, write a data it the ASCII network on the device at:

- Address 5;
- Through Gateway WORD 100 (Address ASCII);
- Address TCP 1000.

In the above scenario:

Specify the type of data between:

- Coil Status (bit in read write);
- Input Status (bit in read);
- Holding Register (word in read and write);
- Input Register (word in read).

From the side of the MODBUS TCP:

- Address of data to read.

From the side of the MODBUS ASCII:

- Address of the device to interrogate;
- Address of data to read on device.

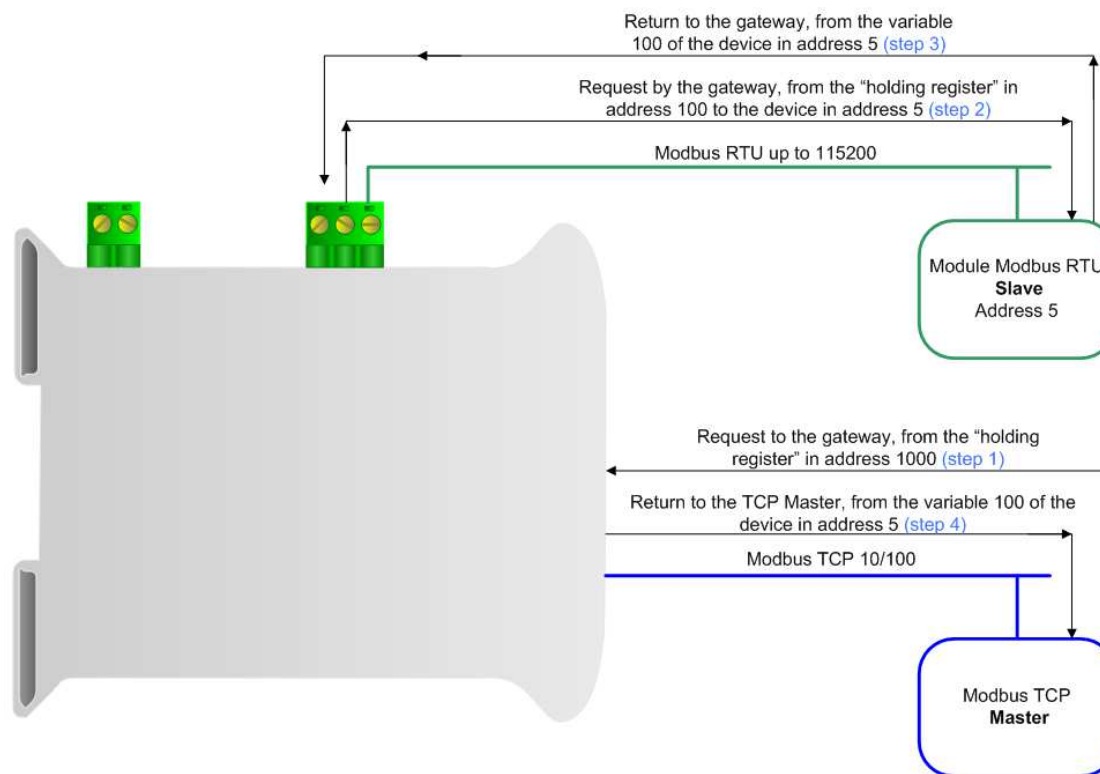

Note: If the ASCII slave responds with an exception, that exception code will be transmitted to the TCP Master. If the ASCII slave does not respond within the estimated time defined by the Timeout parameter, an exception response will be given on TCP side: error code \$0B.

OPERATION MODE (for “Modbus ASCII Slave ↔ Modbus TCP Master”):**NORMAL MODE (WITH TRANSLATE TABLE)**

Using this function, the Converter can be seen like a single serial Modbus slave. The address of Modbus is assigned in the “Set Communication” section.

ROUTING SLAVE ADDRESS

Using this function, the Converter can be seen like more than one serial Modbus slave. Each serial Modbus slave is a row of the table, and it is possible to assign to which TCP device is linked.

WORK WITH FIX IP ADDRESS

Using this function, the Converter can be seen like a single serial Modbus slave. The address of Modbus is assigned in the “Set Communication” section.

In this mode of functioning is not necessary to compile the Translate Table; every request that arrives on serial is transferred on TCP (using TCP format of frame) to the slave with the IP address defined in the “Set Communication” section.

NORMAL MODE (WITH TRANSLATE TABLE):

Using this function, the Converter can be seen like a single serial Modbus slave. The address of Modbus is assigned in the "Set Communication" section.

By pressing the "Translate Table" button from the main window for SW67522 (Fig. 2), the window "Set Translate Table" appears (Fig. 5).

The data of the columns have the following meanings:

- In the field "Data Type" it is possible to select the type of data that is being considered;
- In the field "Address" insert the address of the data on the serial device (Converter);
- In the field "IP Address TCP" insert the IP address of the device on the Modbus TCP that contains the data;
- In the field "Address TCP" insert the address of the data on the TCP device;
- In the field "N° Point" insert the number of consecutive data that you want to configure. For example, you create Address =100, Address TCP=150 and N° point = 5, the following gets set-up automatically: Addresses TCP 150, 151, 152, 153, 154 and the serial Modbus variables 100, 101, 102, 103, 104;
- In the field "Mnemonic" you can insert a brief description.

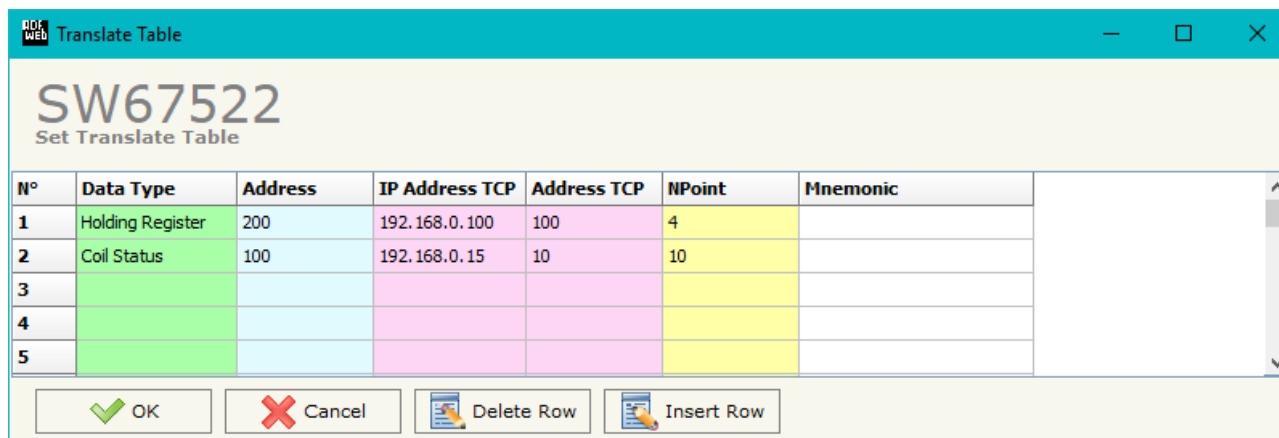

Figure 5: "Set Translate Table" window

EXAMPLE 1:

Taking the first row of Figure 4:

Step 1: A serial Modbus master do the request to the Converter to read the "Coil Status" address 100 for 5 consecutive points;

Step 2: The Converter sends to the TCP Slave 192.168.0.18 the read request of "Coil Status" address 150 for 5 consecutive points;

Step 3: The slave TCP replies to the Converter with the data;

Step 4: The Converter sends back the data on serial.

EXAMPLE 2:

Taking the second row of Figure 4:

Step 1: A serial Modbus master do the request to the Converter to read the "Input Status" address 110;

Step 2: The Converter sends to the TCP Slave 192.168.0.19 the read request of "Input Status" address 100;

Step 3: The slave TCP replies to the Converter with the data;

Step 4: The Converter sends back the data on serial.

EXAMPLE 3:

Taking the third row of Figure 4:

Step 1: A serial Modbus master do the request to the Converter to read the "Holding Register" address 91 for 6 consecutive points;

Step 2: The Converter sends to the TCP Slave 192.168.0.18 the read request of "Holding Register" address 81 for 6 consecutive points;

Step 3: The slave TCP replies to the Converter with the data;

Step 4: The Converter sends back the data on serial.

 **Note:**

If the TCP slave responds with an exception, that exception code will be transmitted to the serial master. If the TCP slave does not respond within the estimated time defined by the Timeout parameter, an exception response will be given: error code \$36.

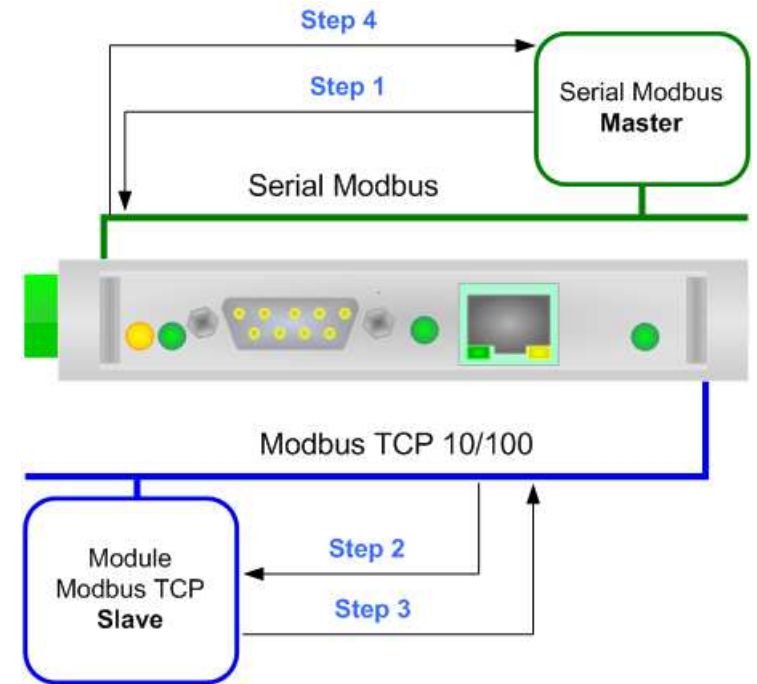

Figure 6: Chart of Request data from serial Modbus

ROUTING SLAVE ADDRESS:

Using this function, the Converter can be seen like more than one serial Modbus slave. Each serial Modbus slave is a row of the table, and it is possible to assign to which TCP device is linked.

By pressing the **“Translate Table”** button from the main window for SW67522 (Fig. 2) the window **“Set Translate Table”** appears (Fig. 7).

The data of the columns have the following meanings:

- In the field **“Slave ID”** insert the virtual address of the device (will be the Converter);
- In the field **“IP Address TCP”** insert the IP address of the device on the Modbus TCP that contains the data;
- In the field **“Slave ID TCP”** insert the address of the device at TCP device;
- If the field **“Reserved Socket”** is checked, the converter will reserve a socket for the specific Modbus TCP slave. This socket will be closed only after the number of consecutive errors defined in the **“Errors Sock”** column. It is possible to reserve up to 3 sockets for 3 different Modbus TCP slaves (function available only for Hardware Version with Dip-Switches).
- In the field **“Mnemonic”** you can insert a brief description.

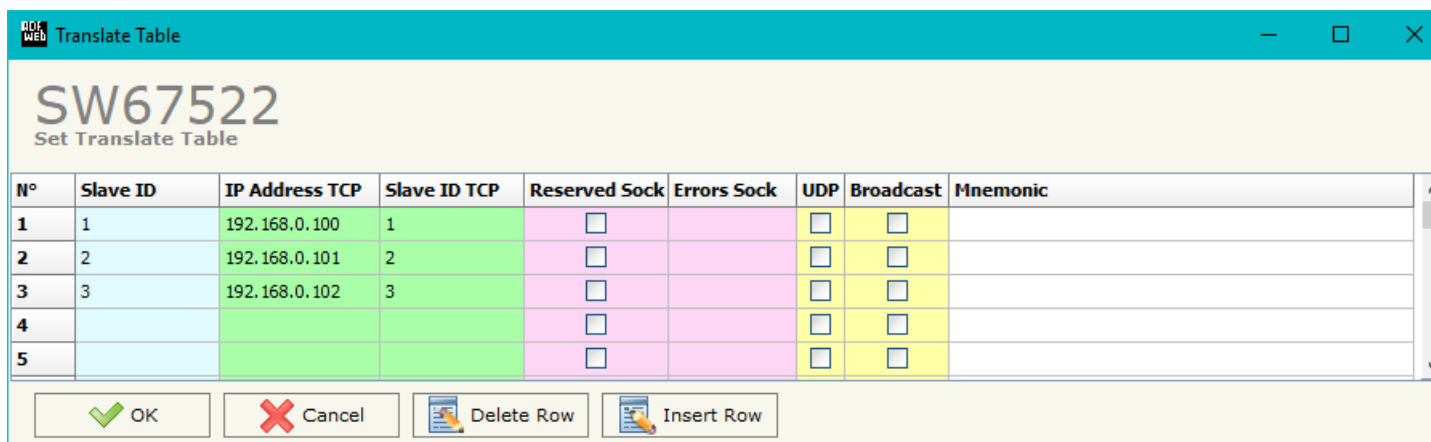

Figure 7: “Set Translate Table” window

EXAMPLE 1:

Taking the first row of Figure 6:

- Step 1:** A serial Modbus master do the request to the Converter to read/write a register from the serial slave Modbus ID 1;
- Step 2:** The Converter sends to the TCP slave 192.168.0.18 the read/write request using the TCP slave ID 5;
- Step 3:** The slave TCP replies to the Converter with the data;
- Step 4:** The Converter sends back the data on serial.

EXAMPLE 2:

Taking the second row of Figure 4:

- Step 1:** A serial Modbus master do the request to the Converter to read/write a register from the serial slave Modbus ID 2;
- Step 2:** The Converter sends to the TCP slave 192.168.0.19 the read/write request using the TCP slave ID 1;
- Step 3:** The slave TCP replies to the Converter with the data;
- Step 4:** The Converter sends back the data on serial.

EXAMPLE 3:

Taking the third row of Figure 4:

- Step 1:** A serial Modbus master do the request to the Converter to read/write a register from the serial slave Modbus ID 4;
- Step 2:** The Converter sends to the TCP slave 192.168.0.20 the read/write request using the TCP slave ID 4;
- Step 3:** The slave TCP replies to the Converter with the data;
- Step 4:** The Converter sends back the data on serial.

Note: If the TCP slave responds with an exception, that exception code will be transmitted to the serial master. If the TCP slave does not respond within the estimated time defined by the Timeout parameter, an exception response will be given: error code \$36.

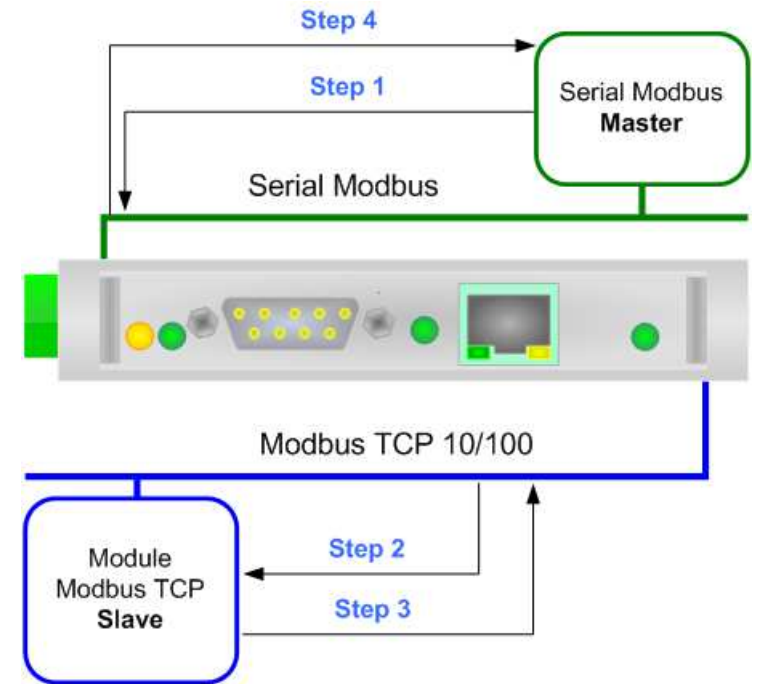

Figure 8: Chart of Request data from serial Modbus

WORK WITH FIX IP ADDRESS:

Using this function, the Converter can be seen like a single serial Modbus slave. The address of Modbus is assigned in the "Set Communication" section.

In this mode of working is not necessary to compile a Translate Table; every request that arrives on serial is transferred on TCP (using TCP format of frame) to the slave with the IP address defined in the "Set Communication" section.

EXAMPLE 1:

Using the configuration of Figure 3:

- Step 1:** A serial Modbus master do the request to the Converter to read/write a register from the ASCII Slave Address 1;
- Step 2:** The Converter sends to the TCP slave 192.168.0.20 the read/write request;
- Step 3:** The slave TCP replies to the Converter with the data;
- Step 4:** The Converter sends back the data on serial.

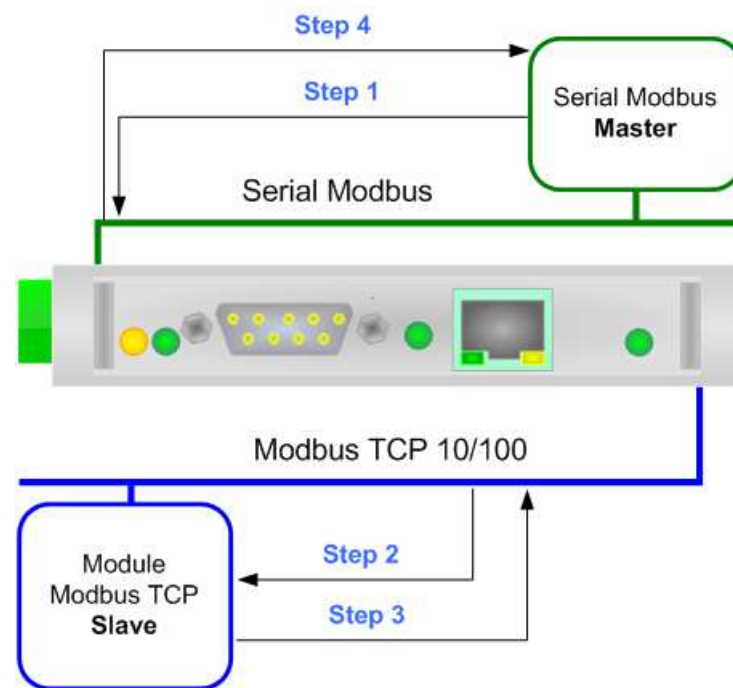

Figure 9: Chart of Request data from serial Modbus

Note: If the TCP slave responds with an exception, that exception code will be transmitted to the serial master. If the TCP slave does not respond within the estimated time defined by the Timeout parameter, an exception response will be given: error code \$36.

UPDATE DEVICE:

By pressing the **Update Device** button, it is possible to load the created Configuration into the device; and also the Firmware, if necessary.

If you don't know the actual IP address of the device you have to use this procedure:

- Turn OFF the Device;
- Put Dip2 of 'Dip-Switch A' in ON position;
- Turn ON the device
- Connect the Ethernet cable;
- Insert the IP **"192.168.2.205"**;
- Select which operations you want to do;
- Press the **Execute update firmware** button to start the upload;
- When all the operations are "OK" turn OFF the Device;
- Put Dip2 of 'Dip-Switch A' in OFF position;
- Turn ON the device.

If you know the actual IP address of the device, you have to use this procedure:

- Turn ON the Device with the Ethernet cable inserted;
- Insert the actual IP of the Converter;
- Select which operations you want to do;
- Press the **Execute update firmware** button to start the upload;
- When all the operations are "OK" the device automatically goes at Normal Mode.

At this point the configuration/firmware on the device is correctly updated.

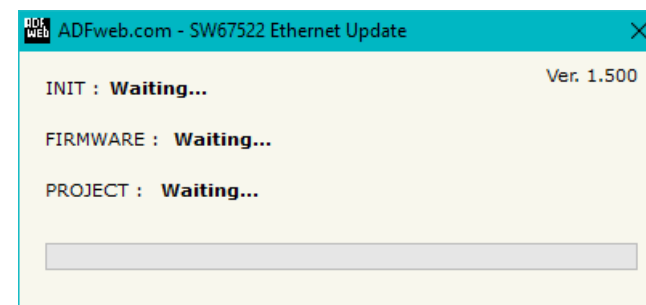
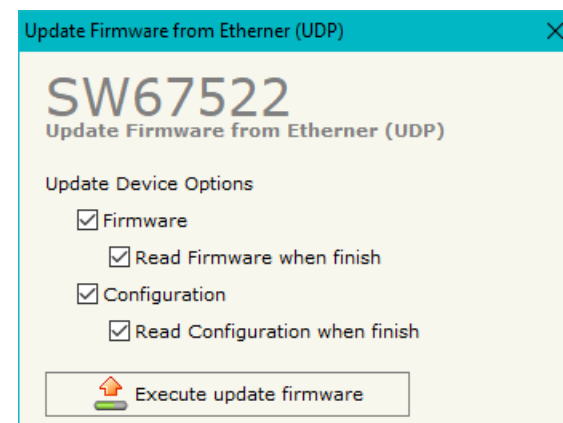
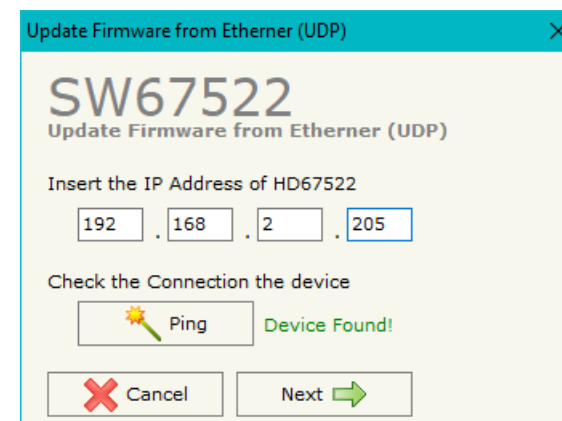

Figure 10: "Update Device" windows

**Note:**

When you install a new version of the software, if it is the first time it is better you do the update of the Firmware in the HD67522 device.

**Note:**

When you receive the device, for the first time, you also have to update the Firmware in the HD67522 device.

**Warning:**

If Fig. 11 appears when you try to do the Update try these points before seeking assistance:

- Try to repeat the operations for the updating;
- Try with another PC;
- Try to restart the PC;
- Check the LAN settings;
- If you are using the program inside a Virtual Machine, try to use in the main Operating System;
- If you are using Windows Seven, Vista, 8 and 10 make sure that you have the administrator privileges;
- In case you have to program more than one device, using the "UDP Update", you have to cancel the ARP table every time you connect a new device on Ethernet. For do this you have to launch the "Command Prompt" and write the command "arp -d". Pay attention that with Windows Vista, Seven, 8 you have to launch the "Command Prompt" with Administrator Rights;
- Pay attention at Firewall lock.

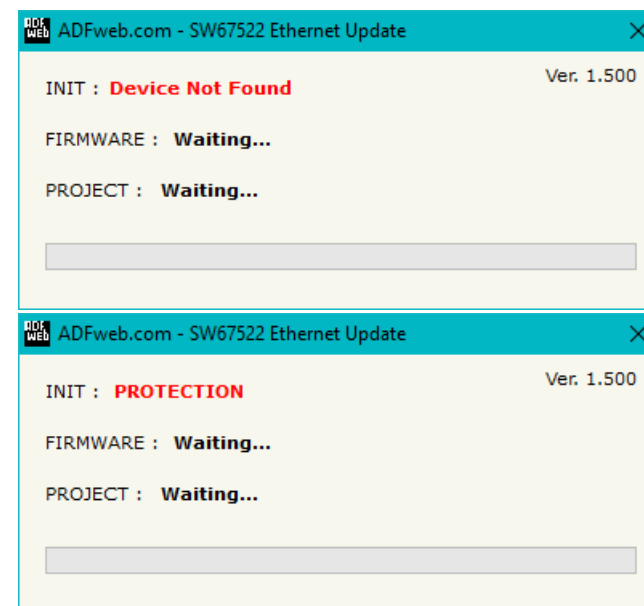
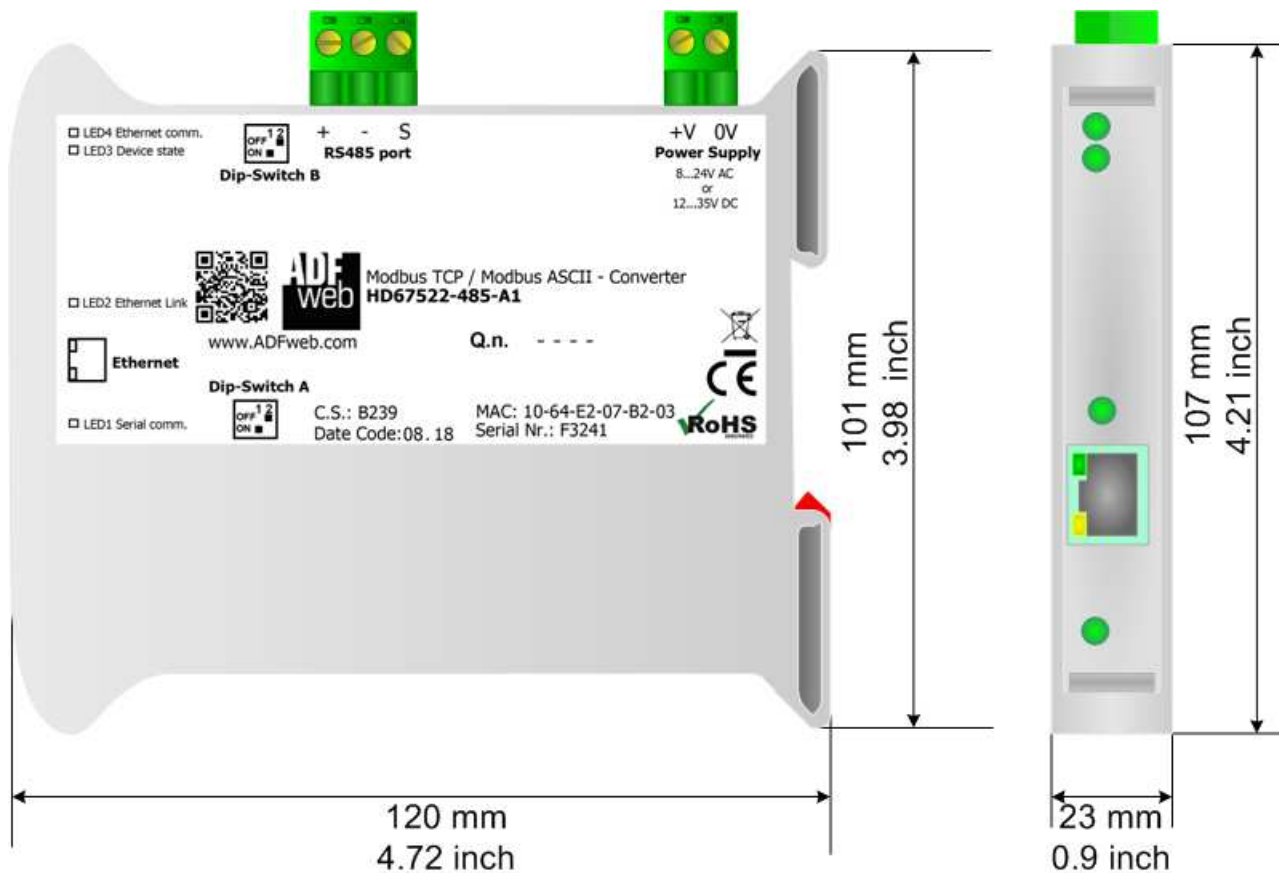

Figure 11: "Protection" window

In the case of HD67522 you have to use the software "SW67522":

www.adfweb.com/download/filefold/SW67522.zip.

MECHANICAL DIMENSIONS:



Housing: PVC
Weight: 200g (Approx)

Figure 12a: Mechanical dimensions scheme for HD67522-xxx-A1

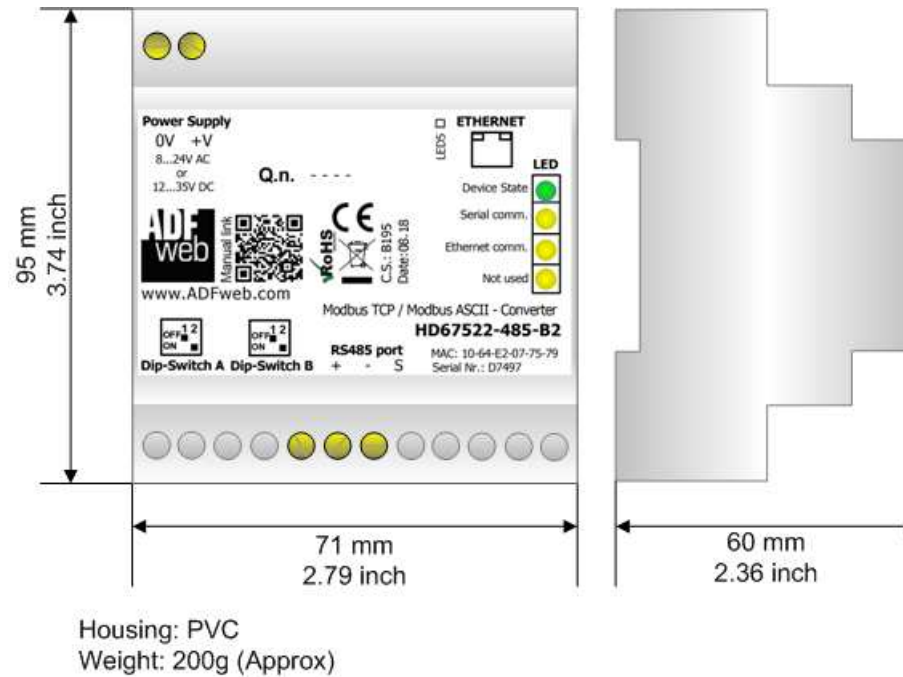
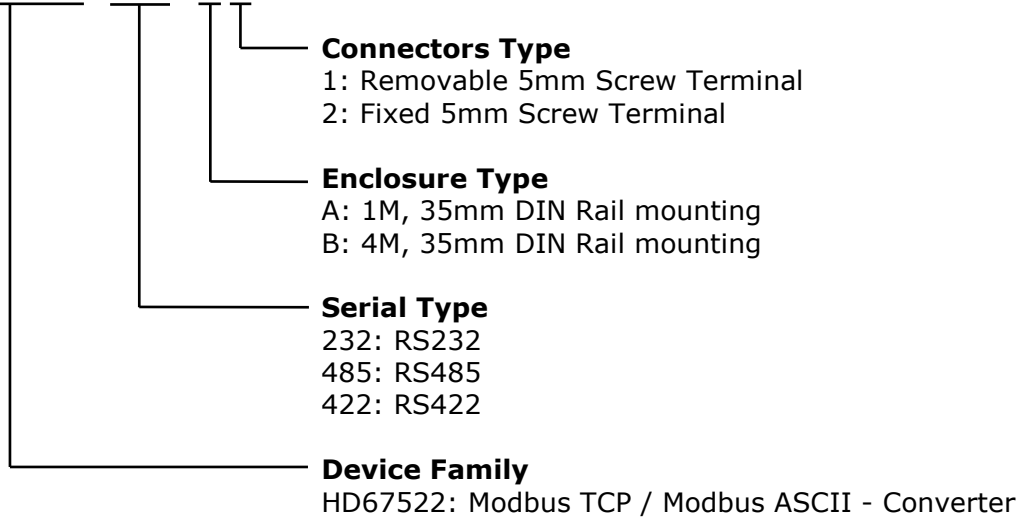

Figure 12b: Mechanical dimensions scheme for HD67522-xxx-B2

ORDERING INFORMATIONS:

The ordering part number is formed by a valid combination of the following:

HD67522 - xxx - x x



- Order Code: **HD67522-232-A1** - Modbus TCP / Modbus ASCII – Converter (RS232 port)
- Order Code: **HD67522-232-B2** - Modbus TCP / Modbus ASCII – Converter (RS232 port)
- Order Code: **HD67522-485-A1** - Modbus TCP / Modbus ASCII – Converter (RS485 port)
- Order Code: **HD67522-485-B2** - Modbus TCP / Modbus ASCII – Converter (RS485 port)
- Order Code: **HD67522-422-A1** - Modbus TCP / Modbus ASCII – Converter (RS422 port)

ACCESSORIES:

- Order Code: **AC34107** - Null Modem Cable Fem/Fem DSub 9 Pin 1,5 m
- Order Code: **AC34114** - Null Modem Cable Fem/Fem DSub 9 Pin 5 m
- Order Code: **AC34001** - Rail DIN - Power Supply 220/240V AC 50/60Hz – 12 V AC
- Order Code: **AC34002** - Rail DIN - Power Supply 110V AC 50/60Hz – 12 V AC

DISCLAIMER:

All technical content within this document can be modified without notice. The content of the document is a under continual renewal. For losses due to fire, earthquake, third party access or other accidents, or intentional or accidental abuse, misuse, or use under abnormal conditions repairs are charged to the user. ADFweb.com S.r.l. will not be liable for accidental loss of use or inability to use this product, such as loss of business income. ADFweb.com S.r.l. shall not be liable for consequences of improper use.

OTHER REGULATIONS AND STANDARDS:**WEEE INFORMATION**

Disposal of old electrical and electronic equipment (as in the European Union and other European countries with separate collection systems).

— This symbol on the product or on its packaging indicates that this product may not be treated as household rubbish. Instead, it should be taken to an applicable collection point for the recycling of electrical and electronic equipment. If the product is disposed correctly, you will help prevent potential negative environmental factors and impact of human health, which could otherwise be caused by inappropriate disposal. The recycling of materials will help to conserve natural resources. For more information about recycling this product, please contact your local city office, your household waste disposal service or the shop where you purchased the product.

RESTRICTION OF HAZARDOUS SUBSTANCES DIRECTIVE

The device respects the 2002/95/EC Directive on the restriction of the use of certain hazardous substances in electrical and electronic equipment (commonly referred to as Restriction of Hazardous Substances Directive or RoHS).

CE MARKING

The product conforms with the essential requirements of the applicable EC directives.

WARRANTIES AND TECHNICAL SUPPORT:

For fast and easy technical support for your ADFweb.com SRL products, consult our internet support at www.adfweb.com. Otherwise contact us at the address support@adfweb.com

RETURN POLICY:

If while using your product you have any problem and you wish to exchange or repair it, please do the following:

- Obtain a Product Return Number (PRN) from our internet support at www.adfweb.com. Together with the request, you need to provide detailed information about the problem.
- Send the product to the address provided with the PRN, having prepaid the shipping costs (shipment costs billed to us will not be accepted).

If the product is within the warranty of twelve months, it will be repaired or exchanged and returned within three weeks. If the product is no longer under warranty, you will receive a repair estimate.



ADFweb.com S.r.l.
Via Strada Nuova, 17
IT-31010 Mareno di Piave
TREVISO (Italy)
Phone +39.0438.30.91.31
Fax +39.0438.49.20.99
www.adfweb.com

